

TGS 4160 - for the detection of Carbon Dioxide

Features:

- * High selectivity to CO₂
- * Low dependency on humidity
- * Long life

Applications:

- * Air quality control
- * CO₂ control in agricultural applications
- * CO₂ monitoring

The **TGS4160** is a hybrid sensor unit composed of a carbon dioxide sensitive element and a thermistor. A wide range of 350~50,000ppm of carbon dioxide can be detected by TGS4160, making it ideal for usage in a variety of applications.

The CO₂ sensitive element consists of a solid electrolyte formed between two electrodes, together with a printed heater (Pt) substrate. By monitoring the change in electromotive force (EMF) generated between the two electrodes, it is possible to measure CO₂ gas concentration.

Adsorbent (zeolite) is filled between the internal cover and the outer cover for the purpose of reducing the influence of interference gases.

TGS4160 exhibits a linear relationship between Δ EMF and CO₂ gas concentration on a logarithmic scale. The sensor displays good long term stability and shows excellent durability against the effects of high humidity.



The figure below represents typical sensitivity characteristics of TGS4160. The Y-axis is indicated as Δ EMF which is defined as follows:

$$\Delta\text{EMF} = \text{EMF1} - \text{EMF2}$$

where

EMF1=EMF in 350 ppm CO₂

EMF2=EMF in listed gas concentration

Sensitivity Characteristics:

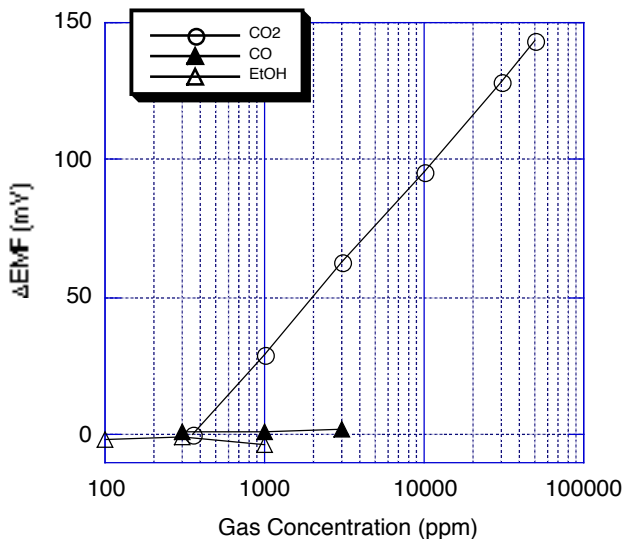

The figure below shows typical humidity dependency for an energized sensor. Again, the Y-axis is indicated as Δ EMF which is defined as follows:

$$\Delta\text{EMF} = \text{EMF1} - \text{EMF2}$$

where

EMF1=EMF in 350 ppm CO₂

EMF2=EMF in 1000ppm CO₂

Humidity Dependency:

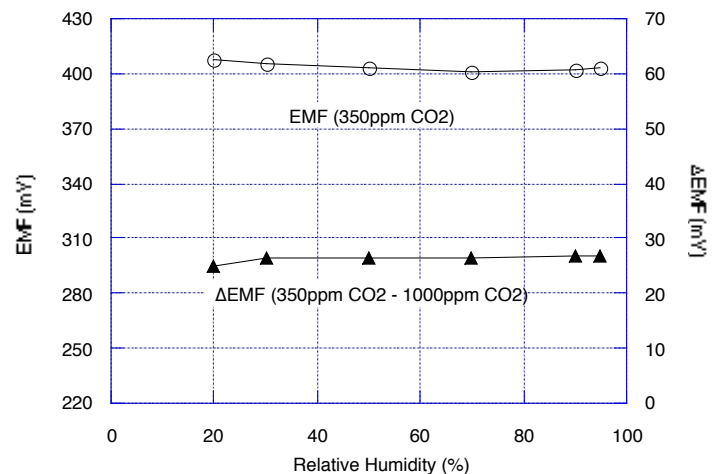

IMPORTANT NOTE: OPERATING CONDITIONS IN WHICH FIGARO SENSORS ARE USED WILL VARY WITH EACH CUSTOMER'S SPECIFIC APPLICATIONS. FIGARO STRONGLY RECOMMENDS CONSULTING OUR TECHNICAL STAFF BEFORE DEPLOYING FIGARO SENSORS IN YOUR APPLICATION AND, IN PARTICULAR, WHEN CUSTOMER'S TARGET GASES ARE NOT LISTED HEREIN. FIGARO CANNOT ASSUME ANY RESPONSIBILITY FOR ANY USE OF ITS SENSORS IN A PRODUCT OR APPLICATION FOR WHICH SENSOR HAS NOT BEEN SPECIFICALLY TESTED BY FIGARO.

Basic Measuring Circuit:

The TGS4160 sensor requires heater voltage (V_H) input. The heater voltage is applied to the integrated heater in order to maintain the sensing element at a specific temperature which is optimal for sensing. Electromotive force (EMF) of the sensor should be measured using a high impedance ($> 100 \text{ G}\Omega$) operational amplifier with bias current $< 1 \text{ pA}$ (e.g. Texas Instruments' model #TLC271). Since the solid electrolyte type sensor

functions as a kind of battery, the EMF value itself would drift using this basic measuring circuit. However, the change of EMF value (ΔEMF) shows a stable relationship with the change of CO_2 concentration. Therefore, in order to obtain an accurate measurement of CO_2 , a special microprocessor for signal processing should be used with TGS4160. Figaro can provide a special evaluation sensor module (AM-4) for TGS4160.

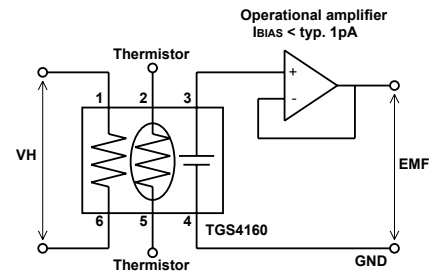

Specifications:

Model number		TGS 4160	
Sensing element type		Solid electrolyte	
Target gases		Carbon dioxide	
Typical detection range		350 ~ 50,000 ppm	
Electrical characteristics under standard test conditions	Heater resistance	R _H	11.5 ± 1.1Ω at room temp.
	Heater current	I _H	approx. 250mA
	Heater power consumption	P _H	approx. 1.25W
	Heater voltage	V _H	5.0 ± 0.2V (DC)
	Electromotive force	EMF	220~490mv in 350ppm CO ₂
	Sensitivity	ΔEMF	44~72mV
Sensor characteristics	Response time	approx. 2 min. (to 90% of final value)	
	Measurement accuracy	approx. ±20% at 1,000ppm CO ₂	
Operating conditions		-10~50°C, 5~95%RH	
Storage conditions		-20~60°C, 5~90%RH (store in moisture proof bag with silica gel)	
Standard test conditions	Test gas conditions	CO ₂ in air at 20±2°C, 65±5%RH	
	Circuit conditions	V _H = 5.0±0.05V DC	
	Conditioning period before test	7 days	

Structure and Dimensions:

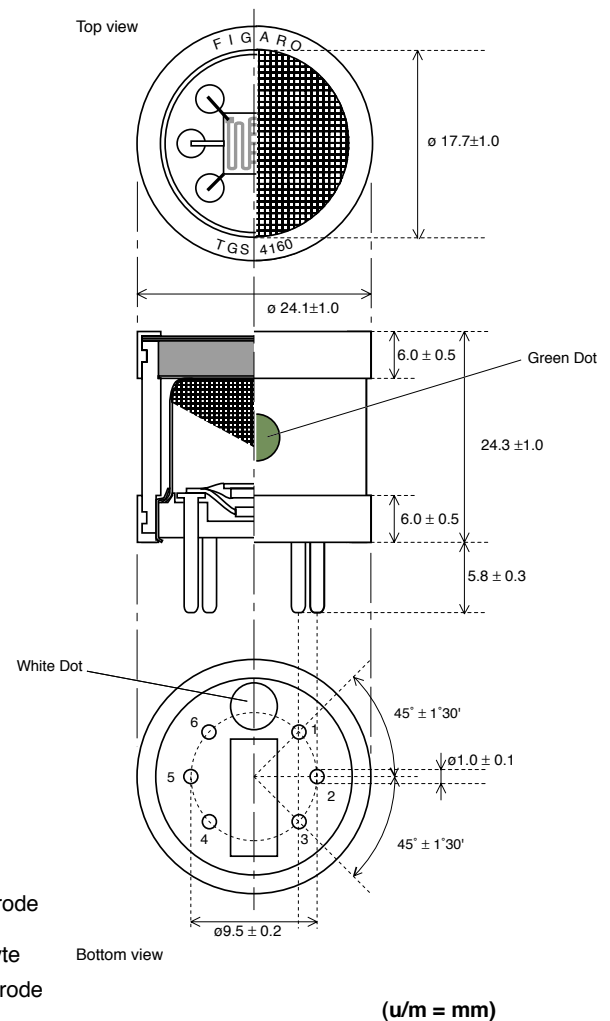

Sensing Element Structure:

Bottom View (Sensor Element)

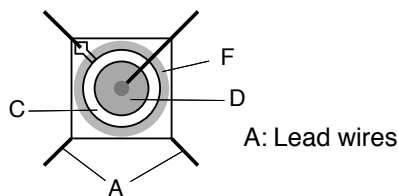

Side view (Sensor Element)

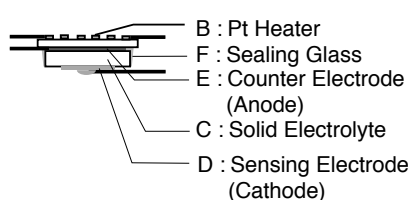

FIGARO ENGINEERING INC.

1-5-11 Senba-nishi
Mino, Osaka 562-8505 JAPAN
Phone: (81)-72-728-2561
Fax: (81)-72-728-0467
www.figaro.co.jp
email: figaro@figaro.co.jp

FIGARO USA, INC.

121 S. Wilke Rd. Suite 300
Arlington Heights, IL 60005 USA
Phone: (1)-847-832-1701
Fax: (1)-847-832-1705
email: figarousa@figarosensor.com

For information on warranty, please refer to Standard Terms and Conditions of Sale of Figaro USA Inc.