

TGS 2616-C00 - for the detection of Hydrogen

Features:

- * High selectivity to hydrogen
- * Small size and low power consumption
- * Uses simple electrical circuit

Applications:

- * Hydrogen detection for steel plant safety
- * Portable gas detectors
- * Leak detection for gas appliances
- * Hydrogen leak detectors for fuel cells
- * Safety measures for lithium-ion batteries

The sensing element is comprised of a metal oxide semiconductor layer formed on an alumina substrate of a sensing chip together with an integrated heater, and it is housed in a standard TO-5 package. In the presence of a detectable gas, the sensor's conductivity increases depending on the gas concentration in the air. A simple electrical circuit can convert the change in conductivity to an output signal which corresponds to the gas concentration.

TGS2616-C00 has a newly developed sensing element which reduces the influence of interference gases such as alcohol, resulting in highly selective response to hydrogen.

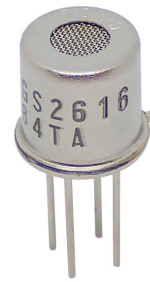

Sensitivity Characteristics:

The figure on the right represents typical sensitivity characteristics that are measured at standard test conditions. (see reverse side of this sheet for more details) The Y-axis indicates sensor resistance ratio R_s/R_0 , where R_s and R_0 are defined as below:

R_s = Sensor resistance in various gases and concentrations
 R_0 = Sensor resistance in 100 ppm of hydrogen

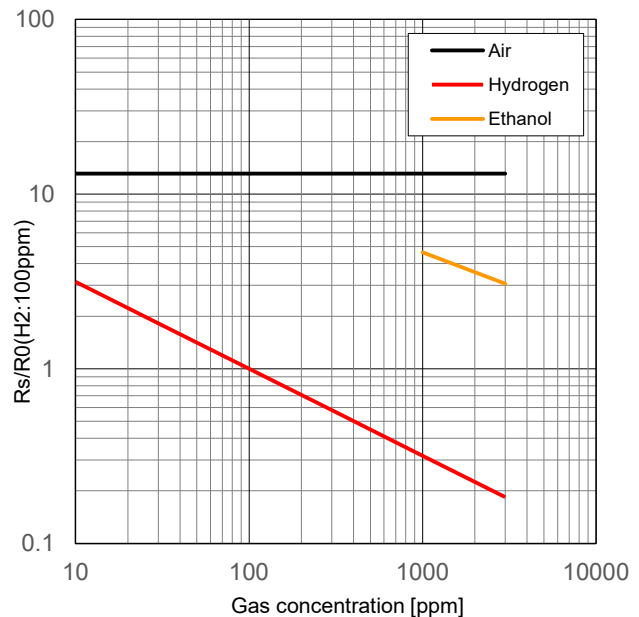

Basic Measuring Circuit:

The sensor requires two voltage inputs: heater voltage (V_H) and circuit voltage (V_C). The heater voltage (V_H) is applied to the integrated heater in order to maintain the sensing element at a specific temperature which is optimal for sensing. Circuit voltage (V_C) is applied to allow measurement of voltage $V_{OUT}(V_{RL})$ across a load resistor (R_L) which is connected in series with the sensor.

A common power supply circuit can be used for both V_C and V_H to fulfill the sensor's electrical requirements. The value of the load resistor (R_L) should be chosen to optimize the alarm threshold value, keeping power dissipation (P_S) of the semiconductor below a limit of 15mW. Power dissipation (P_S) will be highest when the value of R_S is equal to R_L on exposure to gas.

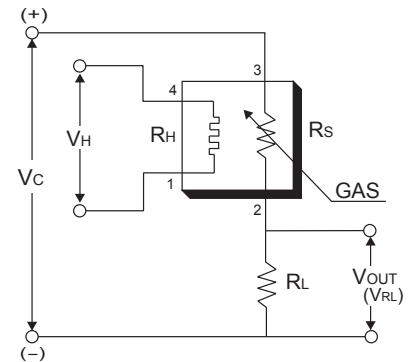

Specifications:

Model number		TGS2616-C00	
Sensing principle		MOS type	
Standard package		TO-5 metal can	
Target gases		Hydrogen	
Typical detection range		30~3000ppm	
Standard circuit conditions	Heater voltage	V_H	5.0±0.2V DC
	Circuit voltage	V_C	5.0±0.2V DC $P_S \leq 15mW$
	Load resistance	R_L	variable 0.45kΩ min.
Electrical characteristics under standard test conditions	Heater resistance	R_H	approx 59Ω at room temp.
	Heater current	I_H	56±5mA
	Heater power consumption	P_H	280mW $V_H = 5.0V$ DC
	Sensor resistance	R_S	0.3kΩ ~ 3.0kΩ in 100ppm hydrogen
Sensitivity (change ratio of R_S)		0.25~0.60 in hydrogen	R_S (1000ppm) / R_S (100ppm)
Standard test conditions	Test gas conditions	Hydrogen in air at 20±2°C, 65±5%RH	
	Circuit conditions	$V_C = 5.0 \pm 0.01V$ DC $V_H = 5.0 \pm 0.05V$ DC	
	Preheating period before test	2 days	

The value of power dissipation (P_S) can be calculated by utilizing the following formula:

$$P_S = \frac{(V_C - V_{RL})^2}{R_S}$$

Sensor resistance (R_S) is calculated with a measured value of $V_{OUT}(V_{RL})$ by using the following formula:

$$R_S = \left(\frac{V_C}{V_{RL}} - 1 \right) \times R_L$$

Structure and Dimensions:

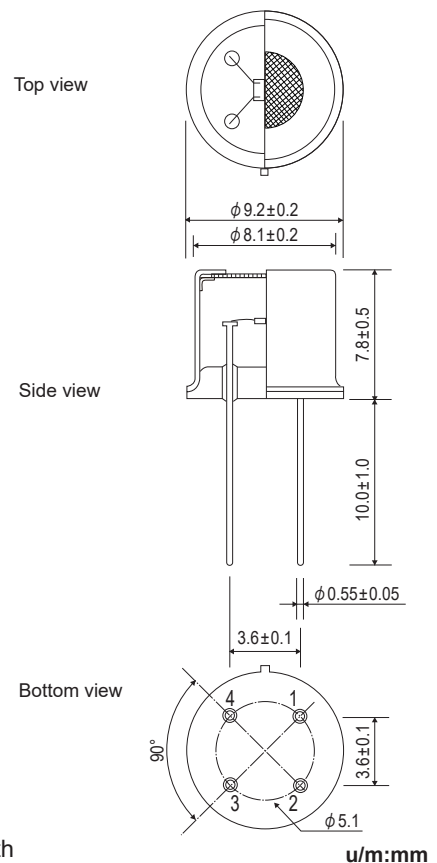

u/m:mm

Pin connection:

- 1: Heater
- 2: Sensor electrode (-)
- 3: Sensor electrode (+)
- 4: Heater

For information on warranty, please refer to Standard Terms and Conditions of Sale of Figaro USA Inc. All sensor characteristics shown in this brochure represent typical characteristics. Actual characteristics vary from sensor to sensor. The only characteristics warranted are those in the Specification table above.

REV: 08/24

Before purchasing this product, please read the Warranty Statements shown in our webpage by scanning this QR code.



https://figarosensor.com/pdf/Figaro_USA_Sales_T&C.pdf

FIGARO USA, INC.

5400 Newport Drive, Suite 19,
Rolling Meadows, IL 60008
Phone: (847)-832-1701

URL: www.figarosensor.com