

TGS 8410 - for the detection of Methane

Features:

- * Low power consumption
- * High sensitivity and selectivity to methane
- * Long life

Applications:

- * Portable/pocket type methane gas detectors
- * Battery operable/wireless gas detectors
- * Leak detection for natural gas vehicles
- * Leak detection for gas pipelines
- * Safety measures for lithium-ion batteries

The sensing element is comprised of a sensing chip and an integrated heater formed on a silicon substrate using MEMS technology, and a metal-oxide semiconductor layer formed on the sensing chip. Due to miniaturization of the sensing chip, **TGS8410** requires a heater power consumption of only 0.087mW(ave.), and is suitable for low-power equipment and battery-operated instruments. In the presence of detectable gas, sensor conductivity increases depending on gas concentration in the air. A simple electrical circuit can convert the change in conductivity to an output signal which corresponds to the gas concentration.

The **TGS8410** uses filter material in its housing for eliminating the influence of interference gases such as alcohol, resulting in highly selective response to methane gas. This feature makes the sensor ideal for residential gas leakage detectors which require durability and resistance against interference gas.



The figure below represents typical sensitivity characteristics, all data having been gathered at standard test conditions (see reverse side of this sheet). The Y-axis is indicated as sensor resistance ratio (R_s/R_o) which is defined as follows:

- R_s = Sensor resistance in displayed gases at various concentrations
- R_o = Sensor resistance in 3000ppm of methane

The figure below represents typical temperature dependency characteristics. Again, the Y-axis is indicated as sensor resistance ratio (R_s/R_o), defined as follows:

- R_s = Sensor resistance in 3000ppm of methane at various temperatures
- R_o = Sensor resistance in 3000ppm of methane at 20°C and 65% R.H.

Sensitivity Characteristics:

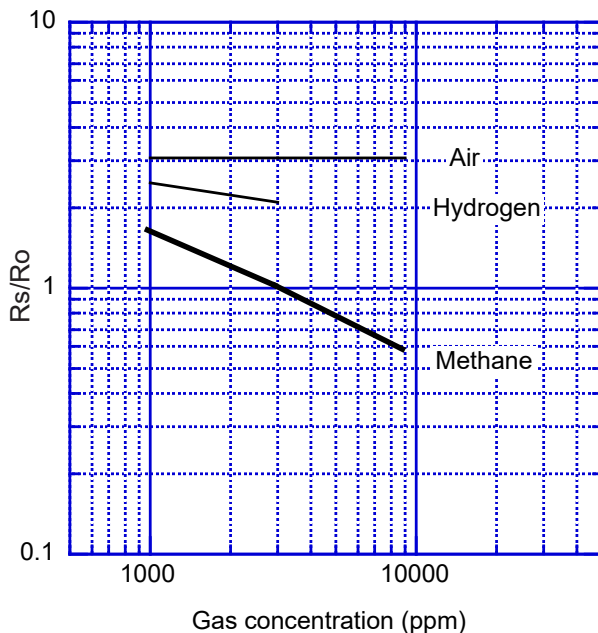

Temperature Dependency:

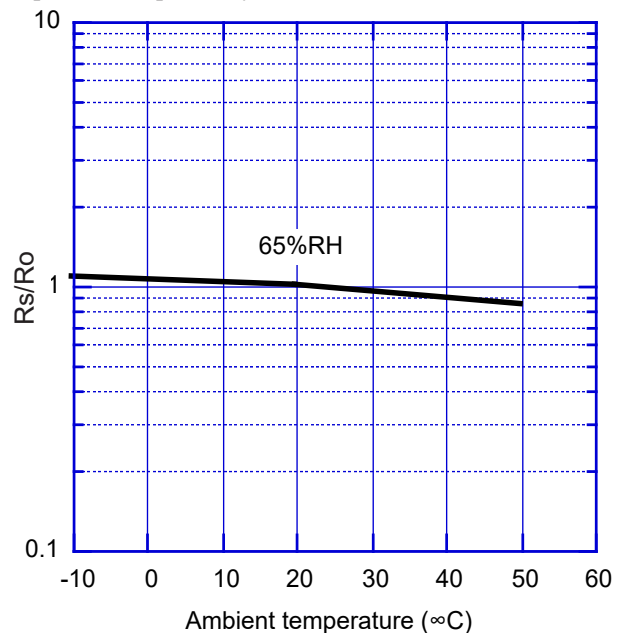

Basic Measuring Circuit:

The sensing element is heated by an integrated heater connected to pin Nos. 1 and 4. The sensor requires application of a 30-second heater voltage cycle comprised of a 1.9V pulse (V_H) being applied to the heater for 0.1 seconds, followed by 0V for the remaining 29.9 seconds.

Circuit voltage (V_C) is applied across the sensing element which has a resistance (R_S) between the sensor's two electrodes (pin Nos. 2 and 3) and a load resistor (R_L) connected in series. A 2.0V circuit voltage pulse is applied for the final 0.002 seconds of each V_H pulse, followed by 0V for the remaining period.

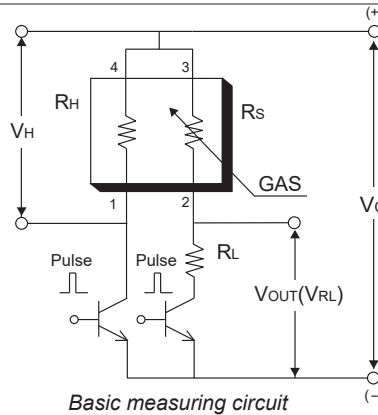

Basic measuring circuit

The sensor's signal should be measured during the 0.002 second V_C pulse (see timing chart). The numbers shown around

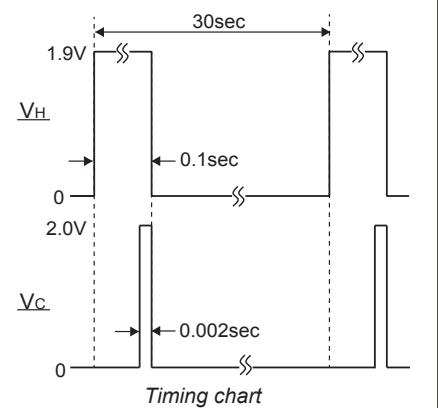

Timing chart

the sensor symbol in the circuit diagram correspond with the pin numbers shown in the structure drawing.

Specifications:

Model number		TGS8410	
Sensing principle		MOS type	
Standard package		TO-5 metal can	
Target gas		Methane	
Typical detection range		1 ~ 25% LEL	
Standard circuit conditions	Heater voltage	V_H	$V_{HH}=1.9V\pm 3\%$ DC for 0.1sec $V_{HL}=0.0V$ for 29.9sec.
	Circuit voltage	V_C	2.0V $\pm 2\%$ DC pulse
	Load resistance	R_L	variable (2k Ω min.)
Electrical characteristics under standard test conditions	Heater resistance	R_H	approx. 60 Ω at room temp.
	Heater current	I_H	12.7~15mA at $V_H=1.9V$
	Heater power consumption	P_H	0.087mW (ave.)
	Sensor resistance	R_S	3~160k Ω in 3000ppm methane
	Sensitivity (change ratio of R_S)	0.48~0.68	$\frac{R_S(3000\text{ppm methane})}{R_S(1000\text{ppm methane})}$
Standard test conditions	Test gas conditions	methane in air at 20 $\pm 2^\circ\text{C}$, 65 $\pm 5\%$ RH	
	Circuit conditions	same as std circuit conditions	
	Conditioning period before test	3 days or longer	

Structure and Dimensions:

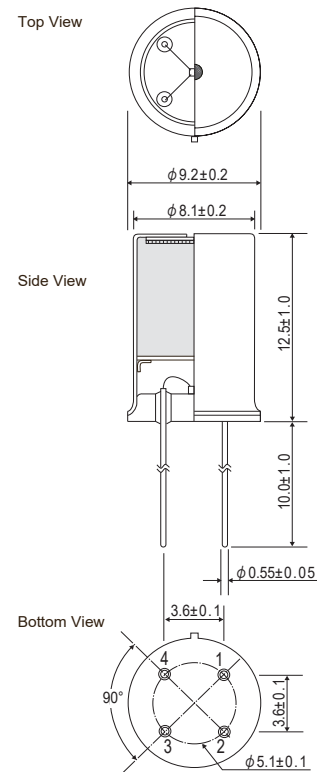

Unit : mm

Pin connection:

- 1:Heater
- 2:Electrode(-)
- 3:Electrode(+)
- 4:Heater

Sensor resistance (R_S) is calculated with a measured value of $V_{OUT}(V_{RL})$ by using the following formula:

$$R_S = \left(\frac{V_C}{V_{RL}} - 1 \right) \times R_L$$

For information on warranty, please refer to Standard Terms and Conditions of Sale of Figaro USA Inc. All sensor characteristics shown in this brochure represent typical characteristics. Actual characteristics vary from sensor to sensor. The only characteristics warranted are those in the Specification table above.

Before purchasing this product, please read the Warranty Statements shown in our webpage by scanning this QR code.



https://figarosensor.com/pdf/Figaro_USA_Sales_T&C.pdf

FIGARO USA, INC.

5400 Newport Drive, Suite 19,
Rolling Meadows, IL 60008
Phone: (847)-832-1701

URL: www.figarosensor.com