

TGS 2612-D00 - for the detection of Methane and LP Gas

Features:

- * Similar sensitivity at same %LEL levels for both methane and LP gas
- * Low power consumption
- * Long life and low cost
- * Uses simple electrical circuit

Applications:

- * Residential LNG and LPG alarms
- * Portable combustible gas leak detectors
- * Detectors for LNG and LPG

The sensing element is comprised of a metal oxide semiconductor layer formed on an alumina substrate of a sensing chip together with an integrated heater. In the presence of a detectable gas, the sensor's conductivity increases depending on the gas concentration in the air. A simple electrical circuit can convert the change in conductivity to an output signal which corresponds to the gas concentration.

The TGS 2612-D00 has high sensitivity to methane, propane and butane, making it ideal for LNG and LPG monitoring. Due to its low sensitivity to alcohol vapors (a typical interference gas in the residential environment), the sensor is ideal for consumer market gas alarms.

Due to miniaturization of the sensing chip, TGS 2612-D00 requires a heater current of only 56mA and the device is housed in a standard TO-5 package.



The figure below represents typical sensitivity characteristics, all data having been gathered at standard test conditions (see reverse side of this sheet). The Y-axis indicates sensor resistance ratio (Rs/Ro) which is defined as follows:

- Rs = Sensor resistance in displayed gases at various concentrations
- Ro = Sensor resistance in 5000ppm of methane

The figure below represents typical temperature and humidity dependency characteristics. Again, the Y-axis indicates sensor resistance ratio (Rs/Ro), defined as follows:

- Rs = Sensor resistance in 5000ppm of methane at various atmospheric conditions
- Ro = Sensor resistance in 5000ppm of methane at 20°C and 65%RH

Sensitivity Characteristics:

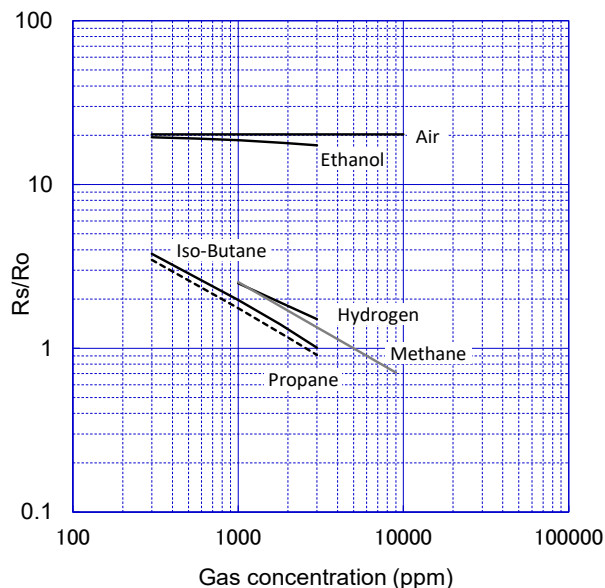

Temperature and Humidity Dependency:

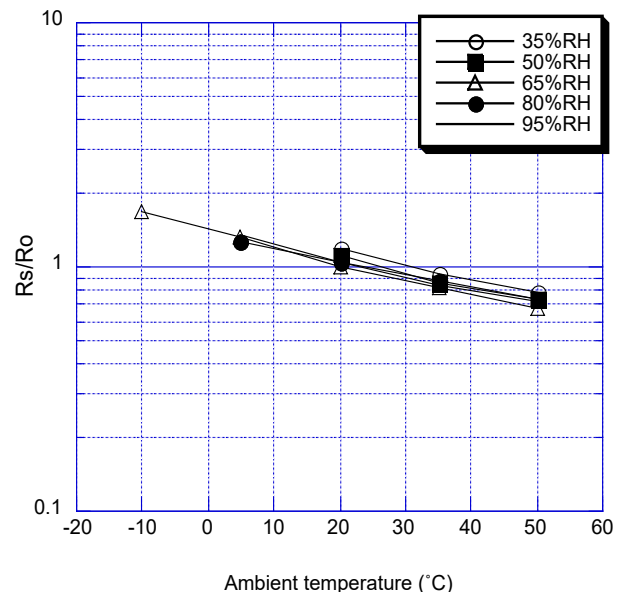

IMPORTANT NOTE: OPERATING CONDITIONS IN WHICH FIGARO SENSORS ARE USED WILL VARY WITH EACH CUSTOMER'S SPECIFIC APPLICATIONS. FIGARO STRONGLY RECOMMENDS CONSULTING OUR TECHNICAL STAFF BEFORE DEPLOYING FIGARO SENSORS IN YOUR APPLICATION AND, IN PARTICULAR, WHEN CUSTOMER'S TARGET GASES ARE NOT LISTED HEREIN. FIGARO CANNOT ASSUME ANY RESPONSIBILITY FOR ANY USE OF ITS SENSORS IN A PRODUCT OR APPLICATION FOR WHICH SENSOR HAS NOT BEEN SPECIFICALLY TESTED BY FIGARO.

Basic Measuring Circuit:

The sensor requires two voltage inputs: heater voltage (V_H) and circuit voltage (V_C). The heater voltage (V_H) is applied to the integrated heater in order to maintain the sensing element at a specific temperature which is optimal for sensing. Circuit voltage (V_C) is applied to allow measurement of voltage $V_{OUT}(V_{RL})$ across a load resistor (R_L) which is connected in series with the sensor.

A common power supply circuit can be used for both V_C and V_H to fulfill the sensor's electrical requirements. The value of the load resistor (R_L) should be chosen to optimize the alarm threshold value, keeping power dissipation (P_S) of the semiconductor below a limit of 15mW. Power dissipation (P_S) will be highest when the value of R_S is equal to R_L on exposure to gas.

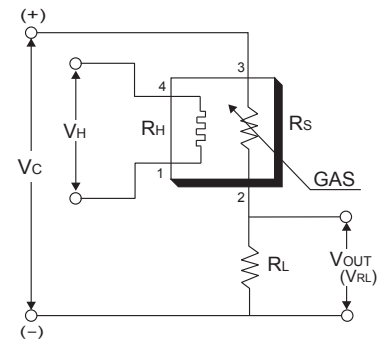

Specifications

Model number		TGS2612-D00	
Sensing principle		MOS type	
Standard package		TO-5 metal can	
Target gases		Methane, propane, iso-butane	
Typical detection range		1 ~ 25%LEL of each gas	
Standard circuit conditions	Heater voltage	V_H	5.0±0.2V DC
	Circuit voltage	V_C	5.0±0.2V DC $P_S \leq 15mW$
	Load resistance	R_L	variable 0.45kΩ min.
Electrical characteristics under standard test conditions	Heater resistance	R_H	approx 59Ω at room temp.
	Heater current	I_H	56±5mA
	Heater power consumption	P_H	280mW $V_H = 5.0V$ DC
	Sensor resistance	R_S	1.2 ~ 12.0kΩ in 5000ppm methane
	Sensitivity (change ratio of R_S)		0.47~0.60 in methane $\frac{R_S(9000ppm)}{R_S(3000ppm)}$
Standard test conditions	Test gas conditions	Methane, propane, iso-butane in air at 20±2°C, 65±5%RH	
	Circuit conditions	$V_C = 5.0 \pm 0.01V$ DC $V_H = 5.0 \pm 0.05V$ DC	
	Preheating period before test	4 days	

The value of power dissipation (P_S) can be calculated by utilizing the following formula:

$$P_S = \frac{(V_C - V_{RL})^2}{R_S}$$

Sensor resistance (R_S) is calculated with a measured value of $V_{OUT}(V_{RL})$ by using the following formula:

$$R_S = \left(\frac{V_C}{V_{RL}} - 1 \right) \times R_L$$

Structure and Dimensions:

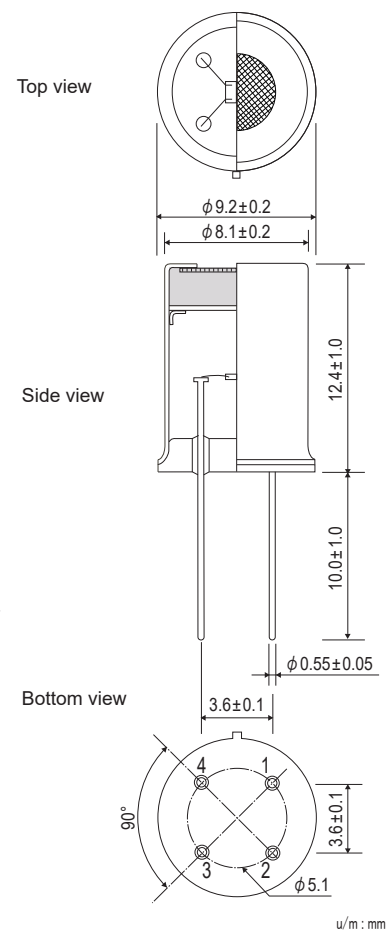

Pin connection:

- 1: Heater
- 2: Sensor electrode (-)
- 3: Sensor electrode (+)
- 4: Heater

For information on warranty, please refer to Standard Terms and Conditions of Sale of Figaro USA Inc. All sensor characteristics shown in this brochure represent typical characteristics. Actual characteristics vary from sensor to sensor. The only characteristics warranted are those in the Specification table above.

REV: 01/24

Before purchasing this product, please read the Warranty Statements shown in our webpage by scanning this QR code.



https://figarosensor.com/pdf/Figaro_USA_Sales_T&C.pdf

FIGARO USA, INC.

5400 Newport Drive, Suite 19,
Rolling Meadows, IL 60008
Phone: (847)-832-1701

URL: www.figarosensor.com