

NGM2611-E13 - pre-calibrated module for Methane

Features:

- * Factory calibrated
- * Temperature compensation circuit
- * Interferent-resistant sensor TGS2611
- * Compact size
- * Meets RoHS regulations

Applications:

- * Residential natural gas alarm

The **NGM2611*** is a pre-calibrated module for natural gas alarms which is precisely calibrated in Figaro's humidity and temperature controlled facility. The module uses **TGS2611-E00** which incorporates a filter to eliminate the influence of interference gases such as alcohol, resulting in highly selective response to methane.

The most important process in manufacturing reliable residential gas alarms is adjusting the alarm point. Calibration is a complicated and time consuming process which also requires a substantial investment in calibration equipment. By eliminating the costly calibration process, this module enables users to easily and simply manufacture residential natural gas alarms. Figaro has taken the complexity out of designing a gas detector circuit by providing users with a temperature compensation circuit which combines a built-in thermistor and individually adjusted load resistor together with Figaro's low power methane gas sensor.

A connector allows easy replacement of the module for the purpose of periodic sensor renewal. This input/output connector enables easy installation of the module into the gas detectors' mother board. This same mother board can be used for both methane and LPG gas detectors by simply changing the module.

This module is designed to meet the performance requirements of EN50194 and UL1484.

Please refer to "Technical Information for TGS2611" for sensor sensitivity characteristics. Refer to "Application Notes for TGS2611" for further information regarding circuit design.

* NGM (Natural Gas sensor Module)

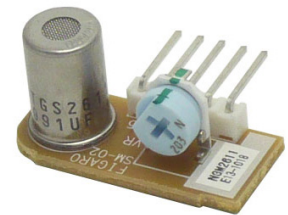

Circuit Diagram

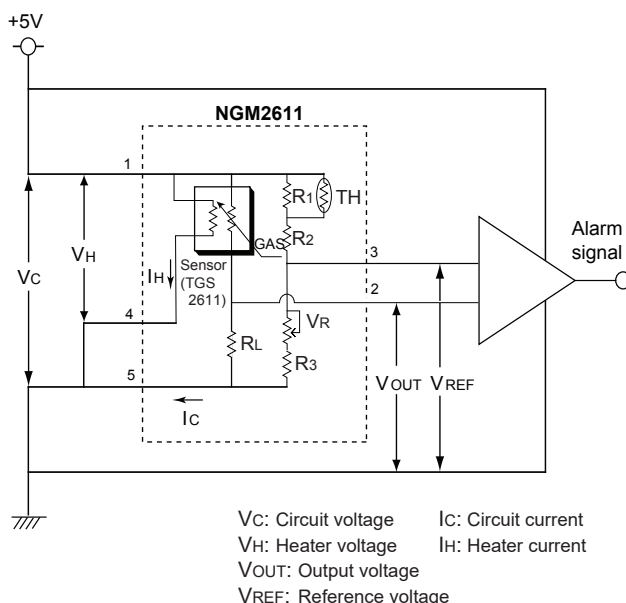

Basic Pin Connection

A regulated voltage of 5V DC should be applied to Pin #1. A voltage comparator should be connected to Pins #2 and 3. A circuit for detecting breakage of the heater may be connected to Pin #4 (in which case, Pins #4 and 5 should be connected separately to the GND).

When the gas sensor module is exposed to a concentration of target gas which exceeds the desired alarming point, the value of V_{out} will reach or exceed the value of V_{REF} , causing the module to reach the alarm condition.

NOTE: As described in Sec. 2-6 of "Technical Information for TGS2611", when energizing the sensor after an unpowered period, the sensor's resistance (R_s) drops sharply for the first few seconds after energizing, regardless of the presence of gases, before recovering to a stable level. This 'initial action' may cause activation of an alarm during the first few moments of energizing since V_{OUT} would exceed V_{ref} . To prevent unnecessary alarms during sensor warmup, a circuit modification such as that shown in Sec. 1-7 of "Application Notes for TGS2611" should be used.

IMPORTANT NOTE: OPERATING CONDITIONS IN WHICH FIGARO SENSORS ARE USED WILL VARY WITH EACH CUSTOMER'S SPECIFIC APPLICATIONS. FIGARO STRONGLY RECOMMENDS CONSULTING OUR TECHNICAL STAFF BEFORE DEPLOYING FIGARO SENSORS IN YOUR APPLICATION AND, IN PARTICULAR, WHEN CUSTOMER'S TARGET GASES ARE NOT LISTED HEREIN. FIGARO CANNOT ASSUME ANY RESPONSIBILITY FOR ANY USE OF ITS SENSORS IN A PRODUCT OR APPLICATION FOR WHICH SENSOR HAS NOT BEEN SPECIFICALLY TESTED BY FIGARO.

Parts List:

Symbol	Part	Spec.	Qty
R1	Carbon resistor	22kΩ	1
R2	Carbon resistor	6.8kΩ	1
R3	Carbon resistor	6.8kΩ	1
RL	Carbon resistor	1.1k~4.7kΩ	1
VR	Potentiometer	20kΩ	1
TH	Thermistor	10kΩ at 25°C B const=3370±1%	1
Sensor	Gas Sensor	TGS2611-E00	1
CN	Connector	Nichiatsu MB5P-90S	1

Specifications:

Module No.		NGM2610-E13
Standard test conditions	Test gas conditions	5000±100ppm methane in air at 20±2°C, 65±5%RH
	Circuit conditions	V _H =5.0±0.05V DC V _C =5.0±0.05V DC
	Preheating period prior to test	2 days
Electrical characteristics under standard test conditions	Reference voltage	V _{REF(STD)} V _{OUT(STD)} ± 0.5V DC
	Output voltage	V _{OUT(STD)} 2.5±0.5V DC

Electrical Characteristics:

Recommended operating conditions	Heater voltage	V _H	5.0±0.2V DC
	Circuit voltage	V _C	5.0±0.2V DC
	Minimum impedance between Pin#2 and GND		2.5MΩ
	Minimum impedance between Pin#3 and GND		
	Operating conditions		0°~40°C, 30~95%RH
Temperature differential between inside and outside detector casing		≤10°C max. (NOTE 1)	
Electrical characteristics under operating conditions	Heater current (current between Pins #1 and 4)	I _H	56±5mA
	Circuit current (current between Pins #1 and 5)	I _C	10mA (max)
	Reference voltage	V _{REF}	1.0~4.0V DC (NOTE 2)
	Output voltage (0~7200ppm iso-butane in air)	V _{out}	0.05~(V _C -0.05)V DC (NOTE 3)

NOTES:

- Due to heat generated by circuit components, if the internal temperature of the detector exceeds the environmental temperature outside the detector casing by 10°C or more, the calibrated alarm concentration would drift due to drifting of V_{ref}. If users are unable to design detectors so as to keep this temperature differential below 10°C, please consult with Figaro.
- Reference voltage may be out of range if temperature exceeds recommended operating conditions.
- Output voltage maybe out of range under the following conditions:
 - * Methane concentration exceeds 20,000ppm
 - * During warm-up period (due to 'initial action' -- refer to Item 2-6 - Initial Action in p.7 of Technical Information for TGS2611)
 Accordingly, it is **STRONGLY RECOMMENDED** to implement a malfunction threshold when using NGM2611-E13.
 - ** Recommended malfunction threshold:
 - 1.0V DC > V_{ref} > 4.0V DC
 - 0.05V DC > V_{out} > (V_C-0.05)V DC

Structure and Dimensions:

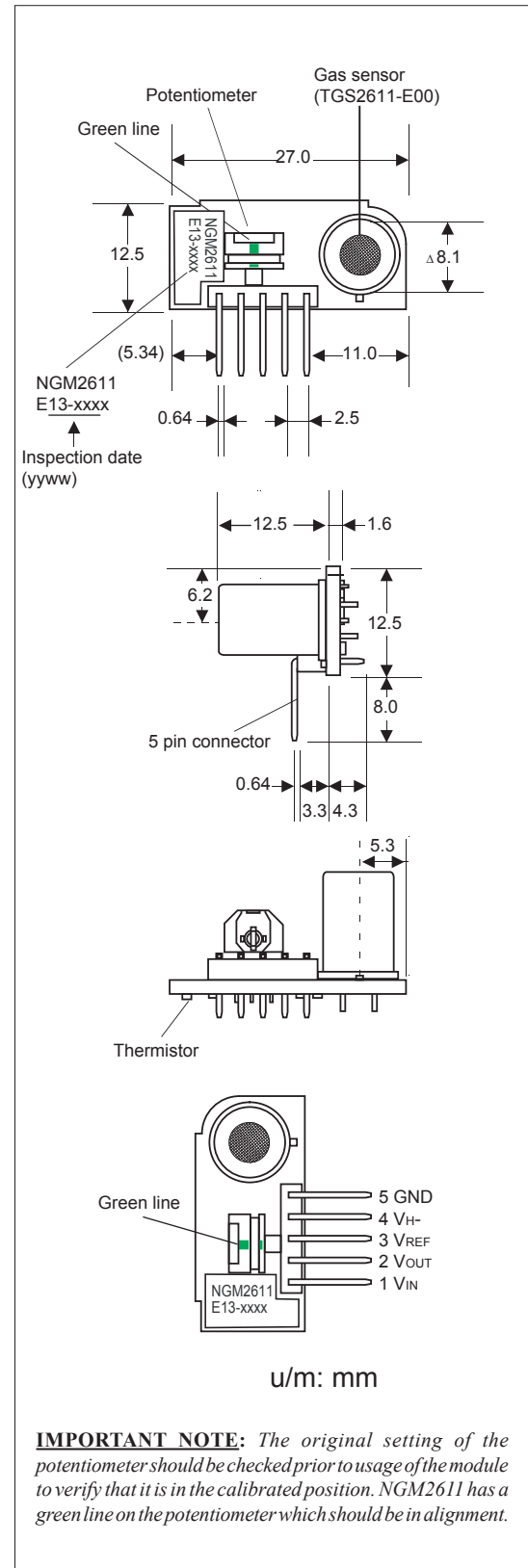

Expected performance:

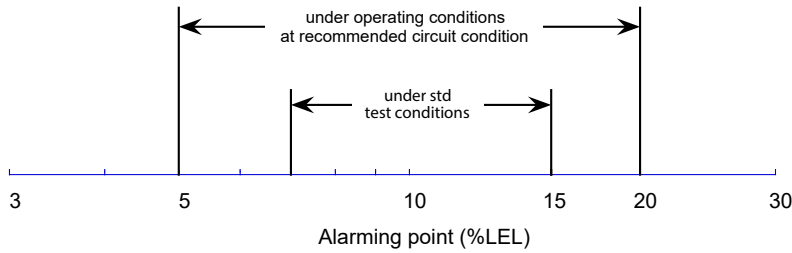

Expected performance of methane gas detectors using NGM2611 and 10% LEL alarming point

NOTE: When using NGM2611, typical alarm tolerances for 10%LEL of methane gas such as those shown in the figure above can be expected. However, in actual usage, alarm thresholds may vary since the threshold is also affected by such factors as the tolerances of test conditions and heat generation inside the gas detection enclosure. As a result, Figaro neither expressly nor impliedly warrants the performance shown in this figure. If a large difference between the expected and actual performance of detectors is noticed, please consult with Figaro.

Absolute Maximum Ratings:

Absolute maximum ratings (see NOTE 4)	Circuit voltage	V _C	-0.3~+5.5V DC
	Heater voltage	V _H	-0.3~+5.5V DC (max of 2 minutes at 5.5V)
	Operating temperature		-15°~+55°C (max 95%RH)
	Storage temperature		-20°~+60°C (avoid condensation)
	Soldering temperature		260°C (max in 10 sec.)

NOTE 1: Detectors should be designed according to "Recommended Operating Conditions" as shown above. However, detector circuits should also be designed not to exceed "Absolute Maximum Ratings" under any circumstances. To exceed these ratings may cause damage or deterioration of the sensor.

For applications involving usage of NGM2611 for applications other than residential natural gas alarms, please consult with Figaro.

For information on warranty, please refer to Standard Terms and Conditions of Sale of Figaro USA Inc. All sensor characteristics shown in this brochure represent typical characteristics. Actual characteristics vary from sensor to sensor. The only characteristics warranted are those in the Specification table above.

Before purchasing this product, please read the Warranty Statements shown in our webpage by scanning this QR code.



https://figarosensor.com/pdf/Figaro_USA_Sales_T&C.pdf

FIGARO USA, INC.

5400 Newport Drive, Suite 19,
Rolling Meadows, IL 60008
Phone: (847)-832-1701

URL: www.figarosensor.com