

Maxell Lead-Free Oxygen Sensors KE-LF Series

Features:

- * **Lead-free galvanic cell-type sensor**
 - no external power supply required for sensor operation
 - no warmup time required
 - meets RoHS2 directive
- * **Weak acid electrolyte**
 - virtually no influence from CO₂, H₂S, SO₂
 - long life - 5 years in ambient air

Applications:

- * **Safety - Oxygen detectors**
- * **Environmental controls - Combustion gas monitoring**
- * **Food industry - Refrigeration, greenhouses**
- * **Educational material - Oxygen test kits**

The Maxell Oxygen Sensor KE-LF Series (KE-25LF and KE-25F3LF) are unique galvanic cell-type oxygen sensors developed by Maxell, Ltd. in Japan. Their most notable features are lead-free, long life expectancy, excellent chemical durability, and no influence by CO₂. KE-LF Series oxygen sensors are ideal to meet the ever-increasing demand for oxygen monitoring in various fields such as combustion gas monitoring, the biochemical field, domestic combustion appliances, etc.



Sensitivity characteristics (typical values under std. test conditions)

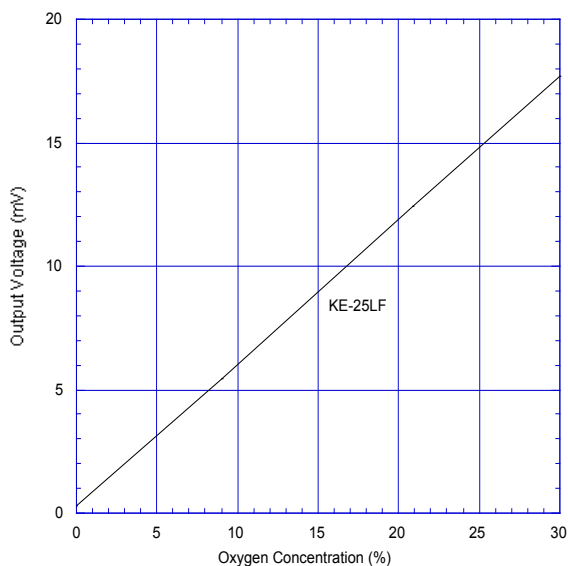

Response time (typical)

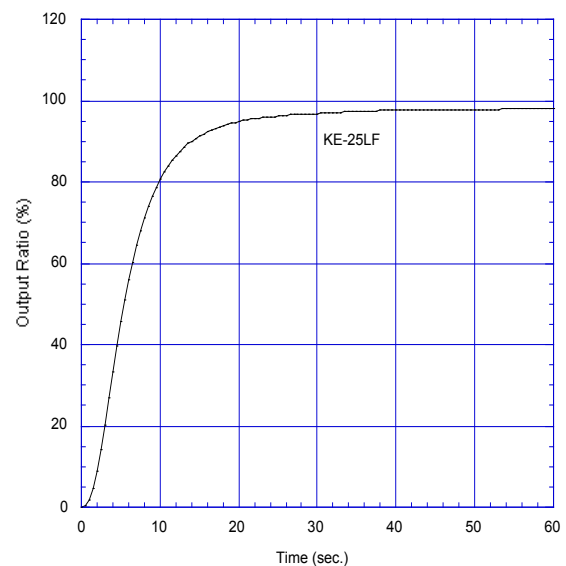

Dimensions

KE-25LF standard version

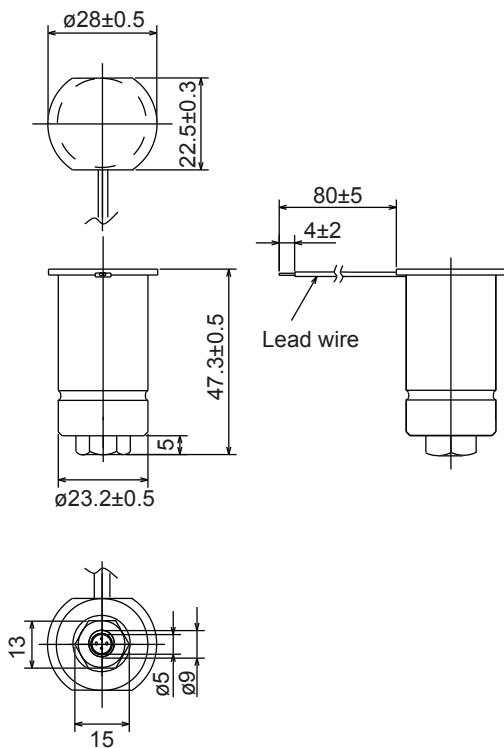

KE-25F3LF (threaded top)

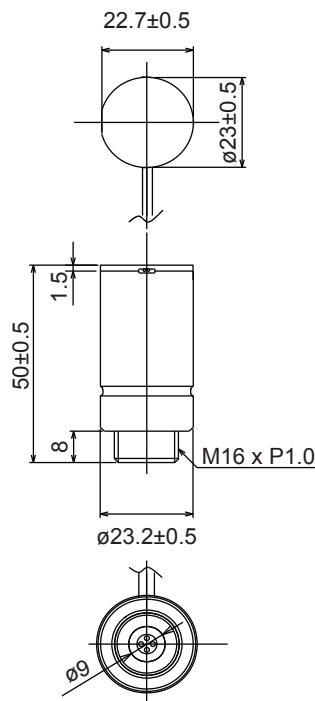

Unit = mm

Specifications

Item	Model	
	KE-25LF	KE-25F3LF
Measurement range	0~30% O ₂	
Accuracy (Note 1)	±1% full scale	
Operating conditions	Atmospheric pressure	811hPa~1216hPa
	Temperature	5~40°C
	Relative humidity	10~90%RH (no condensation)
Response time (90%) (Note 2)	approx 15 sec.	
Initial output voltage under factory std test conditions	10.0~15.5mV	
Life expectancy at 20°C in normal air (Note 3)	approx 5 yrs	

Notes:

1) When calibrated at both 0% and 30% of O₂, accuracy in the range from 0-30% O₂ shall be within ±1% of full scale.

2) Sensors should be used under conditions where the air exchange is greater than 200~300ml per minute in order to obtain the response speed as shown in the Specifications.

3) Life expectancy at 20°C in normal air (1013hPa / 21%O₂) is defined as the period until sensor output drops to 70% of its original value.

* Please refer to the Limited Warranty and Limitation of Liability in *Technical Information for Maxell Oxygen Sensor KE-LF Series*.

* KE-LF series oxygen sensors are designed, manufactured and tested for industrial application only. These products are not designed, manufactured, tested, or intended specifically for use in or incorporation into artificial respirators, ventilators, and/or other equipment for medical application, or subassembly modules or parts thereof. KE-LF series oxygen sensors are not authorized for use as critical components in life support applications wherein a failure or malfunction of the products may result in injury or threat to life.

For information on warranty, please refer to **Standard Terms and Conditions of Sale of Figaro USA Inc.**

Manufacturer: Maxell, Ltd.
 Distributor: **FIGARO USA, INC.**
 121 S. Wilke Rd. Suite 300
 Arlington Heights, IL 60005
 Phone: (847)-832-1701
 Fax: (847)-832-1705
 email: figarousa@figarosensor.com