

CGM6812-B00 - Pre-calibrated module for combustible gas

Features:

- * Linear analog output proportional to gas concentration
- * Maintenance free
- * Compact size
- * Meets RoHS requirements

Applications:

- * Gas leak detection in fuel cell systems
- * Hydrogen & combustible gas leak detectors
- * Safety measures for lithium-ion batteries

The **CGM6812-B00*** combustible gas sensor module is a new unit which utilizes TGS6812, Figaro's catalytic pellistor type gas sensor which features durability and stability. This module provides analog output voltage proportional to hydrogen gas concentration. **CGM6812-B00** has conformal coatings for moisture-proofing and electrical insulation purposes, and is also capable of detecting sensor wire breakage. The unit has a wide range of operating temperature from -10° to +60°C.

Because the TGS6812 sensor can detect methane and LP gas as well as hydrogen, this module is suitable for gas leak detection in stationary fuel cells which use hydrogen generated from combustible gases.

* CGM (Combustible Gas sensor Module)

The figure below represents typical sensitivity characteristics, all data having been gathered at standard test conditions (see reverse side of this sheet). The Y-axis is indicated as output voltage.

Sensitivity Characteristics:

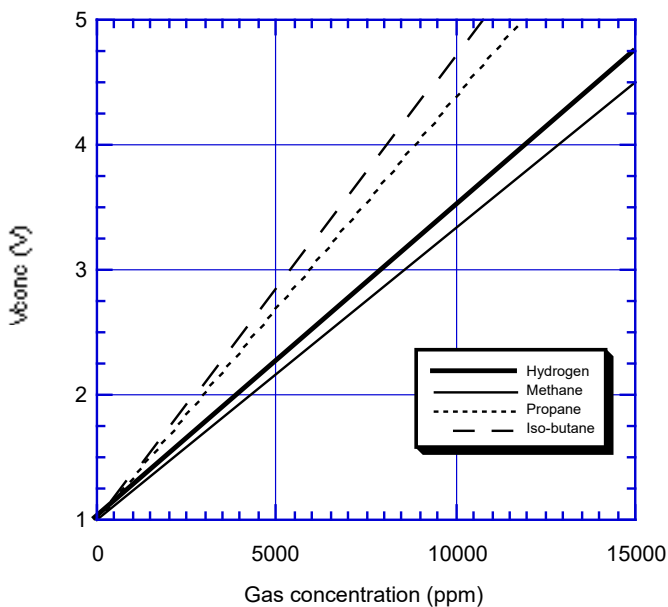

Pin No.	Name	Description
1	GND	Common ground
2	NC	Any connection prohibited
3	NC	Any connection prohibited
4	VCONC	Concentration output voltage
5	VIN	Input voltage

CGM6812-B00 Pin Connections
 (Connector model BH05B-XMSK)
 Recommended receptacle for connector: XMP-05V

IMPORTANT NOTE: OPERATING CONDITIONS IN WHICH FIGARO SENSORS ARE USED WILL VARY WITH EACH CUSTOMER'S SPECIFIC APPLICATIONS. FIGARO STRONGLY RECOMMENDS CONSULTING OUR TECHNICAL STAFF BEFORE DEPLOYING FIGARO SENSORS IN YOUR APPLICATION AND, IN PARTICULAR, WHEN CUSTOMER'S TARGET GASES ARE NOT LISTED HEREIN. FIGARO CANNOT ASSUME ANY RESPONSIBILITY FOR ANY USE OF ITS SENSORS IN A PRODUCT OR APPLICATION FOR WHICH SENSOR HAS NOT BEEN SPECIFICALLY TESTED BY FIGARO.

Specifications:

Product name	Combustible gas sensor module	
Model No.	CGM6812-B00	
Gas sensor	TGS6812 (catalytic type)	
Detection range	0 ~ 14,000ppm H ₂ <i>(also can detect methane, iso-butane, and propane)</i>	
Output voltage (V _{conc})	1~4.5V DC typical (up to max VIN)	
	Conversion to H ₂ concentration	V _{out} =[H ₂ conc(ppm)/4000] + 1.0
	Trouble	V _{conc} =0-0.1V(*)
Factory setting output	V _{conc} in air	1.0±0.2V
	V _{conc} in 8000ppm H ₂	3.0±0.2V
Response time (T ₉₀) to 4000ppm H ₂	≤30 seconds	
Warm-up time (V _{conc} <2.0V)	≤30 seconds (time to V _{conc} <2.0V in air)	
Operating conditions	-10°~+60°C, 20~95%RH (avoid condensation)	
Storage conditions	-10°~+60°C, 20~95%RH	
Input voltage (VIN)	5.0±0.2V DC	
Power consumption	≤1.5W	
Weight	15g or less	
Dimensions	50 x 30 x 25.3mm	
Position dependency	Since the module has position dependency, it should be mounted so the two lug-holes are in a horizontal position	
Standard test conditions	Ambient conditions	20±2°C, 65±5%RH
	Circuit conditions	5.0±0.2V DC
	Preheating period prior to test	≥10 minutes

(*) recommended threshold for trouble detection = 0.2V

The upper opening in the cap of the sensor used in this module (TGS6812) is covered with a double layer of 100 mesh stainless steel gauze (SUS316). Independent tests confirm that this protective cover will prevent the heated sensor elements inside the cap from igniting an explosive mixture of 6.5±0.5% ethylene and air.

Structure and Dimensions:

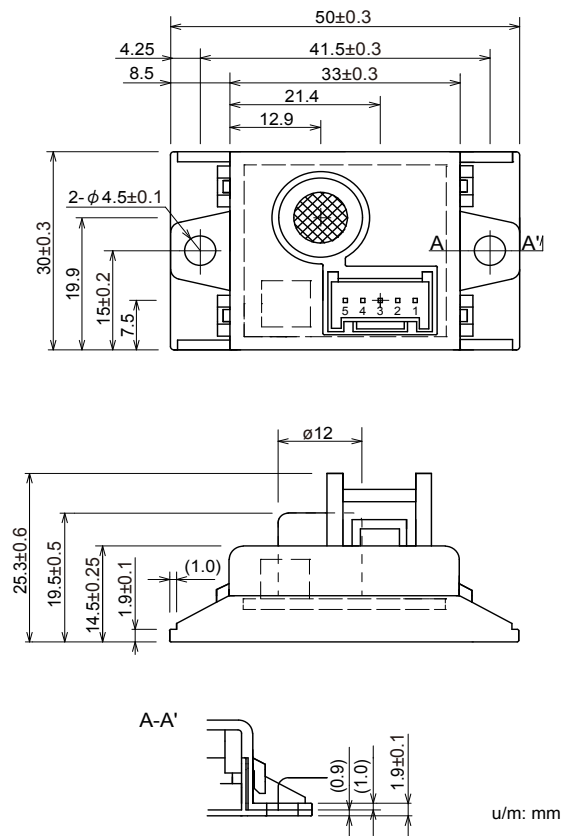

u/m: mm

For information on warranty, please refer to Standard Terms and Conditions of Sale of Figaro USA Inc. All sensor characteristics shown in this brochure represent typical characteristics. Actual characteristics vary from sensor to sensor. The only characteristics warranted are those in the Specification table above.

REV: 01/24

Before purchasing this product, please read the Warranty Statements shown in our webpage by scanning this QR code.



https://figarosensor.com/pdf/Figaro_USA_Sales_T&C.pdf

FIGARO USA, INC.

5400 Newport Drive, Suite 19,
Rolling Meadows, IL 60008
Phone: (847)-832-1701

URL: www.figarosensor.com