

**FIGARO**

an ISO9001/14001 company

# Signal Processing and Calibration Techniques for CO Detectors Using TGS2442

This brochure offers users important technical advice for handling and calibration of the TGS2442 CO sensor, including calibration techniques using a microprocessor. Detector circuit and calibration facility design should be carried out with these points in mind.

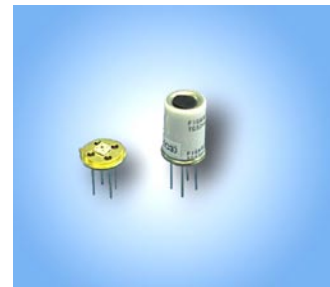

*Page*

*Basic Circuit Structure*.....2

*Method of Signal Processing*

- Basic flow.....2
- Detection of sensor-related trouble conditions.....2
- Calculation of CO concentration
  - Sensor resistance ( $R_s$ ) calculation.....4
  - Temperature compensation of  $f(R_s)$ .....4
  - Compensation for variation in  $R_s$  grades.....5
  - Compensation for variation within  $\beta$  grades.....5
  - Converting  $f(R_s^{\circledast})$  to CO concentration output.....5

*Calibration Using Classified Sensors*

- Preheating.....6
- Pre-calibration
  - Select a load resistor.....6
  - Compensation according to  $\beta$  grade.....6
- Main calibration.....7
- Appendix-Calibration at two or more concentrations.....8

*Ability of Sensor to Meet Performance Standards*

- Requirements of performance standard.....8
- Estimation of calibration accuracy.....9
- Conclusion.....9

**IMPORTANT NOTE:** OPERATING CONDITIONS IN WHICH FIGARO SENSORS ARE USED WILL VARY WITH EACH CUSTOMER'S SPECIFIC APPLICATIONS. FIGARO STRONGLY RECOMMENDS CONSULTING OUR TECHNICAL STAFF BEFORE DEPLOYING FIGARO SENSORS IN YOUR APPLICATION AND, IN PARTICULAR, WHEN CUSTOMER'S TARGET GASES ARE NOT LISTED HEREIN. FIGARO CANNOT ASSUME ANY RESPONSIBILITY FOR ANY USE OF ITS SENSORS IN A PRODUCT OR APPLICATION FOR WHICH SENSOR HAS NOT BEEN SPECIFICALLY TESTED BY FIGARO.

In order to meet the various regulations to which CO detectors are subject, circuit design and method of calibration should be based on the performance of the gas sensor. Recommended procedures for usage of the TGS2442 CO sensor are set forth in this document.

**1. Basic Circuit Structure**

Circuit structure needed to satisfy performance standards should provide for complex signal processing, necessitating usage of a microcomputer with features such as those shown in Table 1. This microcomputer will process multiple signals from the sensor, a thermistor (for temperature compensation), and a potentiometer (for calibration). The microcomputer will output a control signal for alarm operation. The following six types of output signals should be monitored (refer to the sample circuit diagrams and timing charts in Figs. 1 and 2 on the facing page):

- V1: Sampling voltage for gas detection
- V2: Sampling voltage for sensor element trouble detection
- V3: Sampling voltage for reference voltage
- V4: Sampling voltage for temperature compensation
- V5,V6: Sampling voltage for detecting heater trouble

CPU core	4 or 8 bit microcomputer (with 2~8MHz clock)
Memory size	2~4k byte ROM 128~256 nibble or byte RAM
Pin size	28~32 pins
Option	8-bit A/D converter (more than 3 channels) high current direct drive (more than 6 ports)
Mode selection port	select calibration or normal operation modes

Table 1 - Recommended microcomputer features

**2. Method of Signal Processing**

*2-1. Basic flow*

Figure 3 shows the basic flow of detector operation. To avoid potential nuisance alarming during the sensor's initial action period, a warm-up period of several minutes (alarm delay) should be utilized upon initial powering of the detector. After this period, the program in the microcomputer starts the main gas detection routine. During the gas detection routine, the above mentioned six output signals are acquired during each one second interval. V2, V5

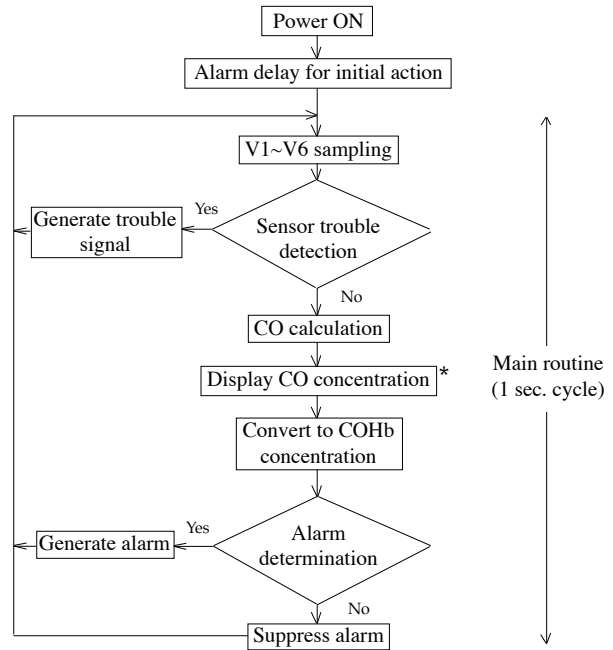

\* if applicable

Figure 3 - Basic flow of detector operation

and V6 are used for detecting sensor-related trouble and heater driving circuit malfunction while V1, V3 and V4 are used to calculate CO gas concentration. This concentration is subsequently converted by time-weighting into a COHb concentration (the key measurement used in performance standards for determining the generation of alarm signals).

*2-2. Detection of sensor-related trouble conditions*

The sensor trouble mode should indicate that the sensor's heater has broken or that the sensor element itself has been damaged. The trouble signal for heater breakage can be detected by an abnormal rise in heater resistance or as a result of lead wire breakage, transistor problems, and/or short of the heater. The sensor element trouble signal is generated by damage to the sensing material or breakage of a lead wire. These phenomena produce an extreme change to the values of V5, V6 and V2; consequently monitoring V5, V6 and V2 enables detection of sensor-related trouble conditions. See Table 2 for recommended conditions for monitoring sensor-related trouble.

Heater trouble	V5 ≥ 0.1V V6 ≤ 4.5V
Sensor element damage	V2 ≤ 0.15V

Table 2 - Conditions under which an trouble signal should be generated

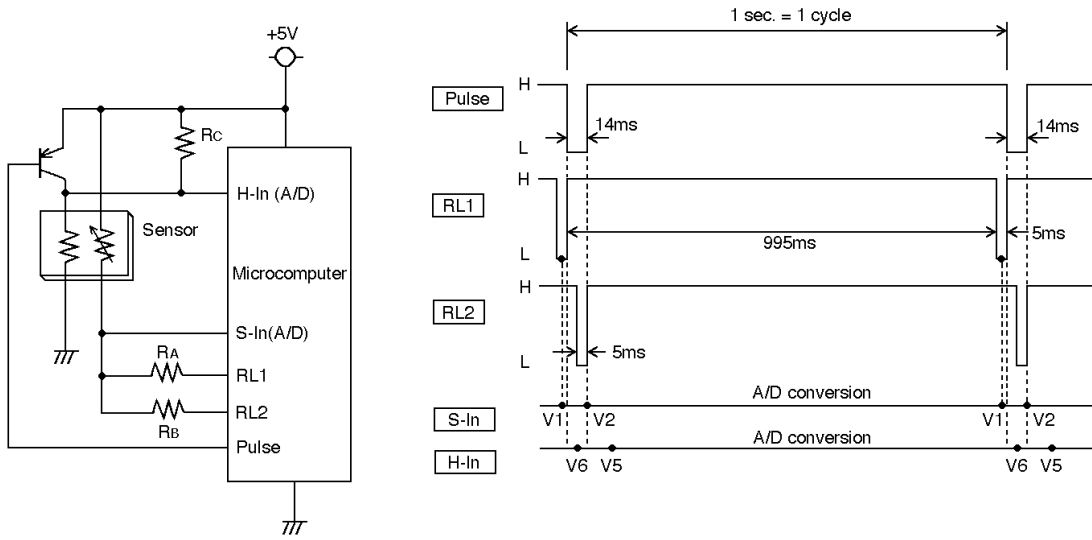

Figure 1 - Basic circuit (including trouble detection)

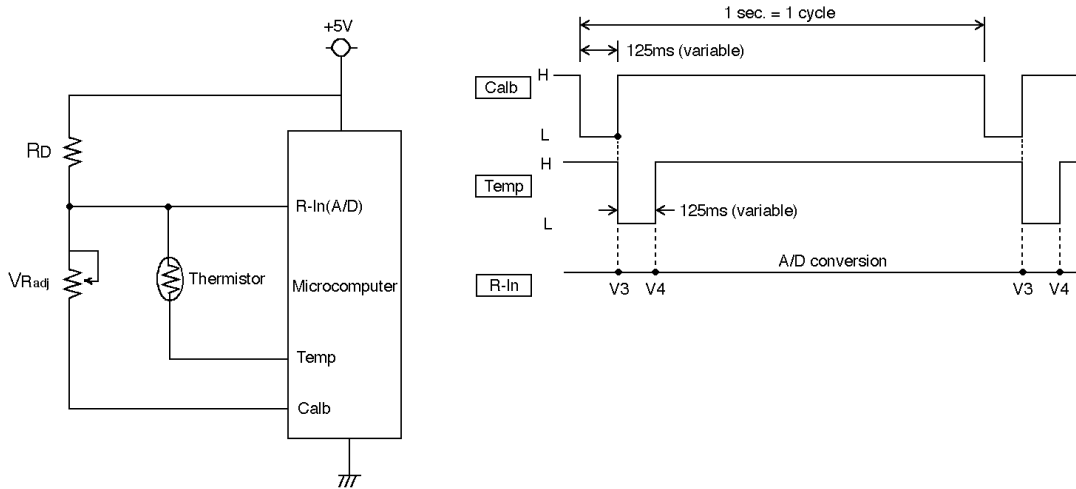

Figure 2 - Calibration & temperature compensation

**Legend of Circuit Diagrams**

S-In 8-bit A/D input port  
 H-In 8-bit A/D input port  
 R-In 8-bit A/D input port

(Each of these ports acquires data at preset timing.)

RL1 open drain output port  
 RL2 open drain output port  
 Pulse open drain output port  
 Temp open drain output port  
 Calb open drain output port

Circuit voltage ( $V_c$ ) across the sensor is applied when RL1 or RL2 ports give the Low (L) output signal at preset timing.

V1 and V2 are acquired during the last half of the 5msec  $V_c$  pulse (the first half of the  $V_c$  pulse is considered as the transient period). V5 is acquired during heater OFF, and V6 is acquired during heater ON pulse.

RA = closest value to  $R_s$  at calibrated CO concentration  
 RB = 300k $\Omega$   
 RC = 10k $\Omega$   
 RD = 20k $\Omega$   
 VRadj = 100k $\Omega$   
 Thermistor: R (25°C) = 15k $\Omega$ , B constant = 4200

2-3. Calculation of CO concentration

Figure 4 illustrates the process for calculating CO concentration from V1, V3 and V4 signals.

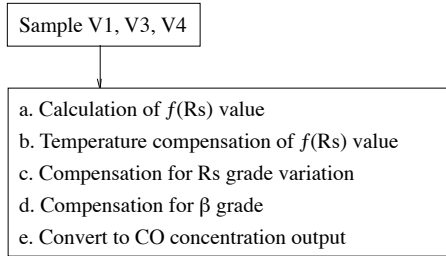

Figure 4 - Signal processing flow for calculation of CO concentration

a. Sensor resistance (Rs) calculation:

To represent sensor resistance (Rs) value in the microcomputer, the expression  $f(Rs)$  shall be used:

$$f(Rs) = (5 - V1) / V1$$

b. Temperature compensation of  $f(Rs)$

In order to compensate for the temperature dependency of  $f(Rs)$  value, a temperature compensation coefficient ( $K_{Temp}$ ) must be determined.

$K_{Temp} = Rs/Ro$ , where  
 Rs = actual sensor resistance in various conditions  
 Ro = actual sensor resistance under standard conditions

Using the circuit condition and recommended thermistor in Figs. 1 & 2, measure actual Rs values at various ambient temperatures and sample thermistor output (V4). The correlation between V4 and  $K_{Temp}$  can be obtained by this procedure and should be written as a table of coefficients into ROM on the microcomputer. Then, by monitoring V4 output during normal operations, the proper  $K_{Temp}$  value can be selected from the table and used to temperature compensate  $f(Rs)$  values according to the following formula:

$$f(Rs^{\circ}) = f(Rs) / K_{Temp}$$

$f(Rs^{\circ})$  represents temperature compensated  $f(Rs)$ . Table 3 shows an example coefficient table for temperature compensation where measuring 100ppm of CO in 25°C/40%RH is used as a standard condition.

Figures 5a and 5b show typical values of  $f(Rs)$  before and after temperature compensation.

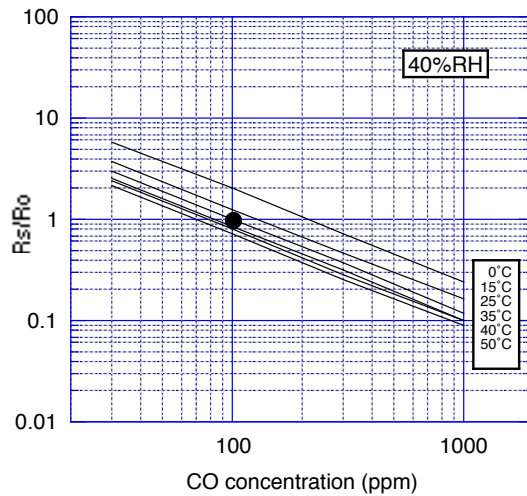

Figure 5a - Temperature dependency of  $R_o$  ( $R_o = R_s$  at 100ppm CO, 25°C/40%RH)

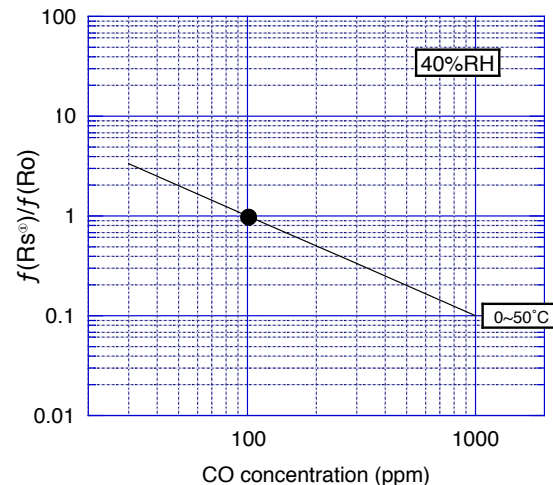

Figure 5b -  $f(Rs^{\circ})$  value compensated for temperature [ $f(Rs^{\circ})$ ] ( $R_o = R_s$  at 100ppm CO, 25°C/40%RH)

V4 Input Value	Temp (°C)	$K_{Temp}$ Coefficient
4.15	-10	2.72
3.92	-5	2.34
3.66	0	1.99
3.37	5	1.70
3.06	10	1.46
2.75	15	1.27
2.44	20	1.12
2.14	25	1.00
1.86	30	0.909
1.61	35	0.839
1.38	40	0.786
1.18	45	0.744
1.01	50	0.712
0.86	55	0.687
0.73	60	0.668

Table 3 - Table of temperature compensation coefficients

c. Compensation for variation within Rs grades

Variation in absolute Rs values among sensors within any given grade should be normalized by adjusting  $f(R_{ref})$  as part of the calibration process.

$$f(R_{ref}) = (5 - V3) / V3$$

$f(Rs^*)$  is defined as a variation compensated  $f(Rs^*)$  value:

$$f(Rs^*) = f(Rs^*) / f(R_{ref})$$

To calibrate the sensor correctly,  $f(Rs^*)$  should be equal to 1.0 at the desired concentration. To do this, change V3 values by adjusting VRadj. Figures 6a and 6b show the variation within Rs grades and the result of compensating for such Rs variation.

d. Compensation for variation within  $\beta$  grades

Variation in sensitivity slopes ( $\alpha$ ) among sensors within any  $\beta$  grade should be compensated in the calibration process. This requires that a second  $f(Rs^*)$  value (at 300ppm of CO, for example) be obtained:

- \* measure actual  $f(Rs)$  at second CO concentration
- \* calculate  $f(Rs^*)$  for the second concentration
- \* using the  $f(Rs^*)$  values for the two concentrations, calculate the slope ( $\alpha$ ):

$$\alpha = \frac{\log f(Rs^*) (300\text{ppm}) - \log f(Rs^*) (100\text{ppm})}{\log 300 - \log 100}$$

- \* store the  $\alpha$  value in the microcomputer

e. Converting  $f(Rs^*)$  to CO concentration output

Using the sensitivity curve slope ( $\alpha$ ) determined above, actual CO concentration (C) can be calculated for usage in conversion to COHb:

$$C = 100 \times f(Rs^*)^{1/\alpha}$$

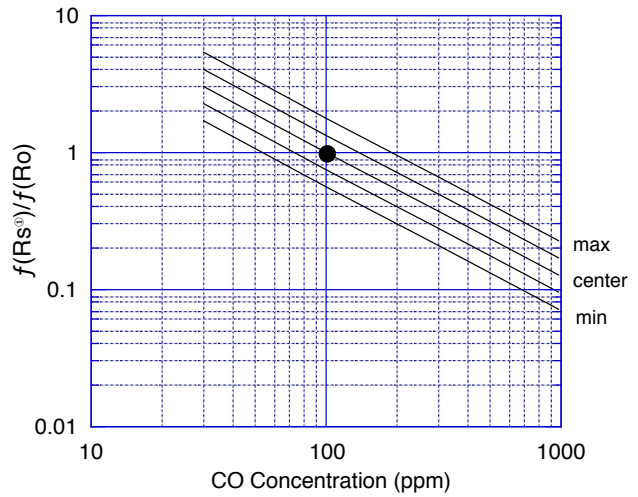

Figure 6a - Rs variation within Rs grades  
( $R_o = R_s$  at 100ppm CO, 25°C / 40%RH)

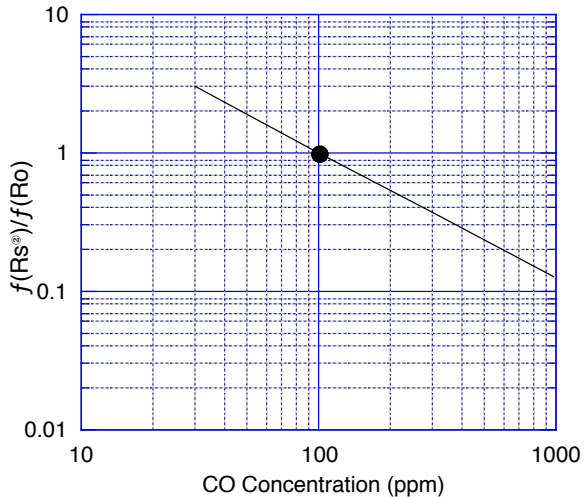

Figure 6b - Rs variation compensation  
( $R_o = R_s$  at 100ppm CO, 25°C / 40%RH)

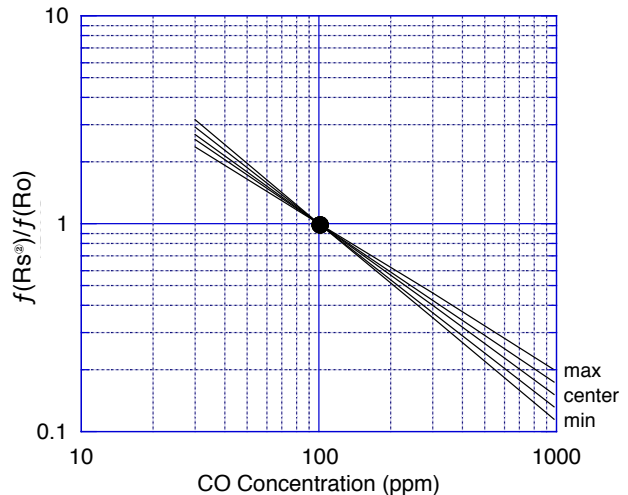

Figure 7 -  $\alpha$  variation within  $\beta$  grades  
( $R_o = R_s$  at 100ppm CO, 25°C / 40%RH)

### 3. Calibration Using Classified Sensors

This section describes the procedure for calibrating at 100ppm of CO using sensors classified as shown in Tables 4 and 5. Figure 8 illustrates the flow of the calibration process, including the method of signal processing which takes place in the microcomputer.

#### 3-1. Preheating

To stabilize sensor characteristics prior to calibration, it is recommended that sensors be preheated under standard circuit conditions for 2 - 7 days. To shorten preheating time and simplify this process, Figaro is currently studying alternative methods and will issue new recommendations shortly.

#### 3-2. Pre-calibration (adjustment during assembly)

##### a. Select a load resistor (RL)

Select the load resistor (RL, same as RA in Figure 1) based on the Rs grade shown in Table 4. For optimal resolution, the RL used should have a value as close as possible to the Rs grade's center value. The sensor output signal (V1) at the calibration concentration should be near 2.5V which is 1/2 the value of Vc. According to the maximum and minimum values of Rs values for each Rs grade as shown in Table 4, V1 would fall in the following range:

$$1.70 \text{ v} \leq V1 \text{ (at 100ppm)} \leq 3.30 \text{ v}$$

##### b. Compensation according to β grade

Each Rs grade is divided into six β grades as shown in Table 5. Using data from this table, α values for these grades can be determined as follows and should be stored in the microcomputer (see Table 6):

$$\alpha = \log \beta \text{ (center)} / \log (300/100)$$

Using the α value calculated above, compensation for β grade can be done by utilizing a circuit such as that shown in Figure 9 and connecting the three jumper lines as indicated in Table 6.

Grade	Rs in CO 100ppm (kΩ)			Recommended RL (kΩ)
	Min.	Center	Max.	
1	6.81	12.1	21.5	12
2	10.0	17.8	31.6	18
3	14.7	26.1	46.4	27
4	21.5	38.3	68.1	39

Table 4 - Rs grades of TGS2442

Grade	β (Rs in 300ppm/Rs in 100ppm)		
	Min.	Center	Max.
A	0.230	0.285	0.340
B	0.260	0.315	0.370
C	0.290	0.345	0.400
D	0.320	0.375	0.430
E	0.350	0.405	0.460
F	0.380	0.435	0.490

Table 5 - β grades of TGS2442

β Grade	α Value	Jumper Connection
A	-1.14	001
B	-1.05	010
C	-0.969	011
D	-0.862	100
E	-0.823	101
F	-0.758	110

Table 6 - Recommended jumper connections for β grade compensation circuit

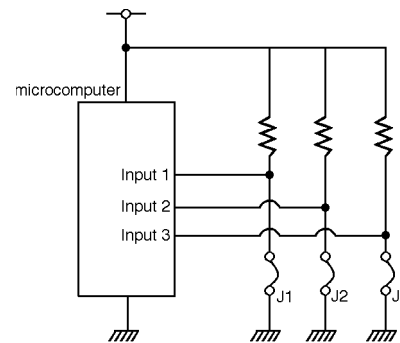

Figure 9 - Recommended circuit for β grade compensation

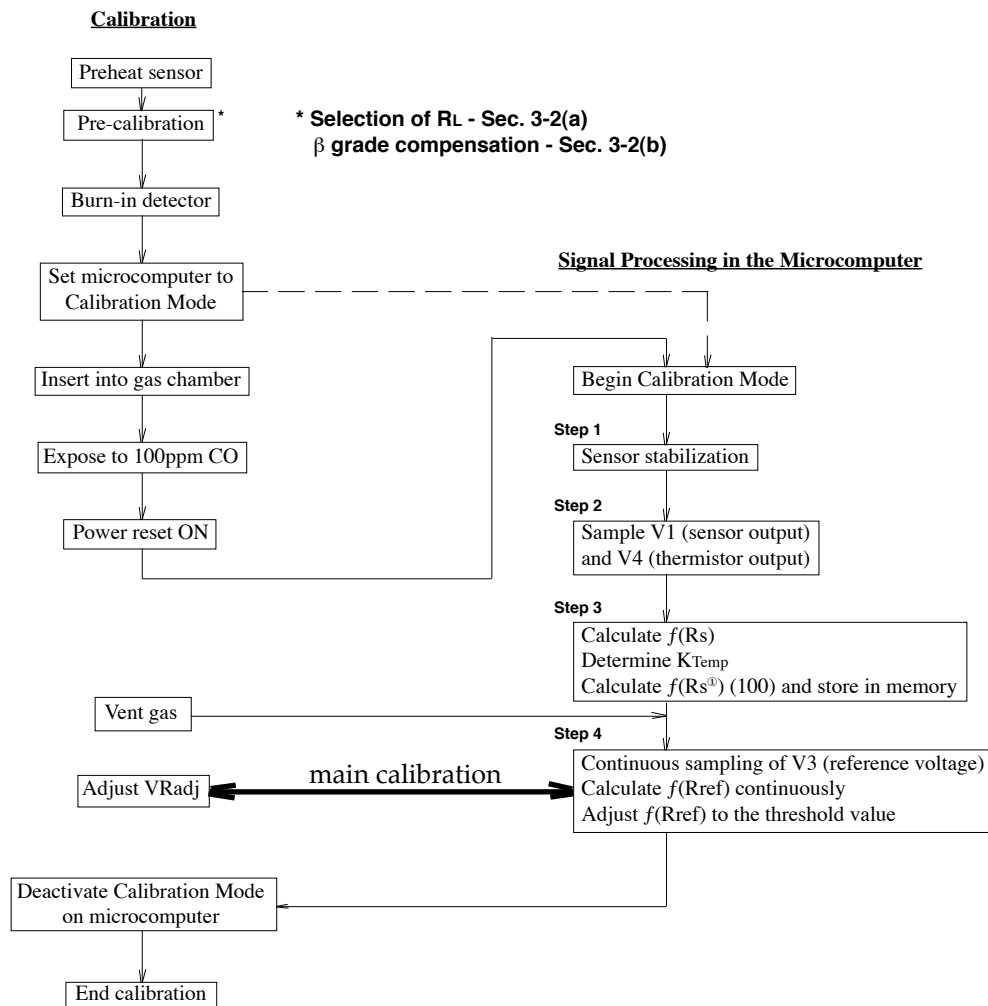

Figure 8 - Calibration and signal processing in the microcomputer

3-3. Main calibration (using “Calibration Mode” in the microcomputer)

Using the mode selection port on the microcomputer, select “Calibration Mode”. Switch the detector ON (Reset), activating calibration mode. Signal processing in the microcomputer during the calibration mode proceeds as shown in Figure 8. Place the detector in a vessel which is then filled with 100ppm of CO.

**Step 1:**

Stabilize sensor output V1 in 100ppm of CO for the predetermined period stored in the microcomputer.

**Step 2:**

Obtain V1 and V4 at the conclusion of stabilization.

**Step 3:**

Calculate  $f(R_s)$ ,  $K_{Temp}$ ,  $f(R_s^0)$  according to the procedure in Section 2-3(a,b). The value  $f(R_s^0)$  is stored temporarily in the microcomputer’s RAM.

**Step 4:**

After ventilating the calibration gas, V3 is continuously monitored and converted to  $f(R_{ref})$  [see equation in 2-3(c)]. Using a potentiometer (VRadj), adjust  $f(R_{ref})$  to equal  $f(R_s^0)$  in 100ppm of CO which was memorized in Step 3. This procedure can be simplified by directing the microcomputer to activate an LED when  $f(R_{ref})$  is set to the correct level.

For example: If  $f(R_{ref}) = [f(R_s^0)(100ppm)] \pm 3\%$ , then “LED TURN ON” else “LED TURN OFF”

Appendix-Calibration at two or more concentrations

Detectors which display CO concentration demand more accurate calculation of CO concentrations. To obtain sufficient accuracy, calibration should be conducted at two or more CO concentrations according to the signal processing procedures in Section 2. For illustration, an example of 300ppm and 100ppm of CO as calibration points is used in this section.

The procedure of compensation according to  $\beta$  grade in Section 3-2(b) may be omitted. Instead,  $f(Rs^\circ)$  of a second CO concentration (300ppm in this case) is obtained by following Steps 1~ 4 in Section 3-3. By this procedure, the sensor's  $\beta$  value can be obtained for each detector from the following equation:

$$\beta = f(Rs^\circ)(300ppm) / f(Rs^\circ)(100ppm)$$

In turn, this  $\beta$  value can be converted into an  $\alpha$  value by using the equation shown in Section 3-2(b). This  $\alpha$  value ( $\alpha_{mem}$ ) is temporarily stored in the RAM of the microcomputer (see Sec. 2-3(d)).

To compensate for the slope of the sensitivity curve, a slope compensation circuit shown in Figure 10a can be used. Since the range of values for V7 is from 0 ~ 5V and the range of  $\alpha$  values is from -1.4 ~ -0.6, a linear relationship between the V7 and  $\alpha$  can be established (see Figure 10b). Then, in order to compensate for  $\alpha$  value, the V7 port is used--adjust the potentiometer (VRadj2) so that the  $\alpha_{calb}$  value is set as close to  $\alpha_{mem}$  as possible. This procedure can be simplified by directing the microcomputer to activate an LED when  $\alpha$  is set to the correct level:

For example: If  $\alpha_{calb} = \alpha_{mem} \pm 3\%$ ,  
then "LED TURN ON" else "LED TURN OFF"

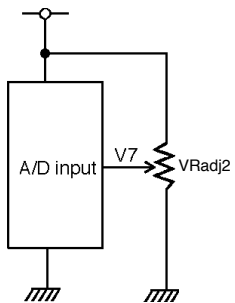

Figure 10a - Slope compensation circuit

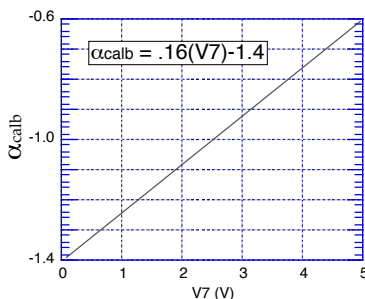

Figure 10b - Relationship of slope (a) to V7

Following these procedures, each sensor can be fully compensated for temperature and sensitivity slope.

4. Ability of Sensor to Meet Performance Standards

This section will show how TGS2442, if used in the manner described in this document, can satisfy CO detector performance standards such as UL2034 and the CSA 6-96 standard. The following assumptions are made for this purpose:

- \* no error exists in calibration gas concentration
- \* no adjustment error in VRadj exists
- \* the gas sensitivity curve is linear on a logarithmic scale between 60-600ppm of CO
- \* no error exists in temperature compensation

Under these conditions, accuracy of calibration will depend upon the accuracy of  $f(Rs)$  and  $\beta$ . When calibration is done using two or more CO concentrations (Section 3-Appendix), calibration without error can be done at the targeted gas concentration. However, if calibration is done only at one gas concentration and is based on one of the combinations of  $R_s$  and  $\beta$  grades supplied for the sensor, since  $\beta$  falls within a range for each grade, verification that such variation in  $\beta$  falls within acceptable limits is required.

4-1 Requirements of performance standard

The most stringent performance standard (CSA 6-96) requires that an alarm be generated at not less than 5% COHb but less than 10% COHb. The specified CO concentration and accumulation times for each

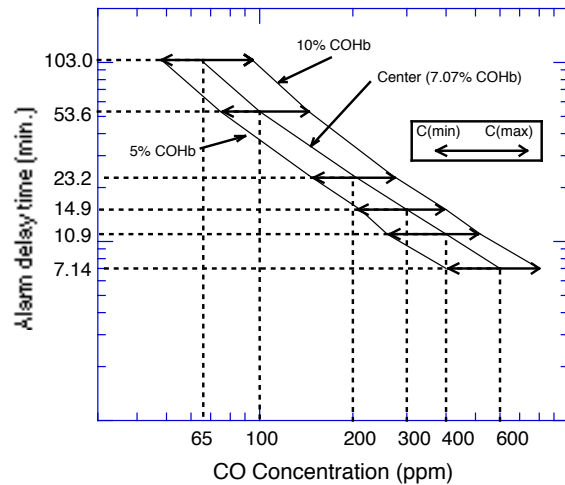

Figure 11 - Alarm times permitted by performance standard

concentration are spelled out by the standard. While the standard lists specific delay times allowed for each CO concentration, to facilitate this discussion the permissible range of CO concentrations at each specific delay time will be used.

The maximum and minimum values of alarming time permitted by the standard for each CO concentration are plotted on the chart shown in Figure 11. The log center between these two curves (7.07% COHb) is also plotted. From these curves, the values of concentration width allowed at each delay time can be determined—see Table 7 for a listing of these values.

4-2 Estimation of calibration accuracy

The variation in each  $\beta$  grade can be illustrated as in Figure 12. The center line is based on the  $\beta$  center value which is given to each sensor grade. At the calibration point of 100ppm, the  $f(Rs^*)$  value of each sensor would be the same ( $f(Rs^*) = 1.0$ ). But at 60 and 600ppm, the  $f(Rs^*)$  could vary as shown in the chart. At each concentration of CO, the center  $f(Rs^*)$  can be identified and the +/- range of  $f(Rs^*)$  values can also be determined. If the maximum and minimum  $f(Rs^*)$  values fall within the allowable ranges of the standard (Table 7), then sensors calibrated at one CO concentration could satisfy the requirements of the performance standards. Table 8 shows maximum and minimum CO concentrations for each sensor grade compared to the range of CO concentrations permitted by performance standards.

4-3 Conclusion

As Table 8 illustrates, properly calibrated TGS2442 sensors can satisfy the requirements of current performance standards even if calibrated with only

one CO concentration. This verification is based on the aforementioned assumptions. Any factors which may influence these assumptions should be taken into consideration when planning actual detector design and when designing the calibration process.

Alarm time (t <sub>conc.</sub> ) in minutes	CO Concentration (ppm)		
	C (min)	C (center)	C (max)
t <sub>65</sub> = 103	48	65	95
t <sub>100</sub> = 53.6	75	100	145
t <sub>200</sub> = 23.2	145	200	270
t <sub>300</sub> = 14.9	210	300	400
t <sub>400</sub> = 10.9	260	400	520
t <sub>600</sub> = 7.14	400	600	800

Table 7 - CO concentration ranges vs. alarm times as specified by performance standard

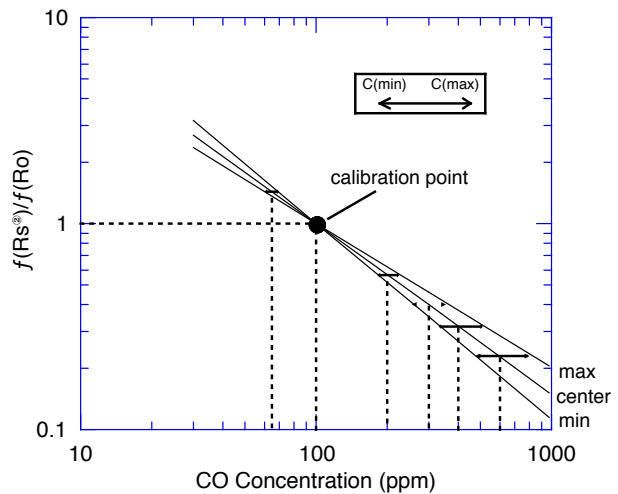

Figure 12 - Variation of alarm concentrations in  $\beta$  grades ( $R_o = R_s$  at 100ppm CO, 25°C/40%RH)

Test Point $\beta$ Grade	CO Concentration Range (ppm)				
	65ppm	100ppm	200ppm	300ppm	400ppm
A	60.6-69.0	100	181-224	257-358	329-500
B	60.6-69.0	100	182-224	257-359	330-501
C	60.6-69.0	100	182-224	258-359	330-502
D	60.5-69.0	100	182-225	257-360	330-504
E	60.4-69.1	100	181-225	257-362	329-507
F	60.3-69.1	100	181-225	256-365	329-511
Standard Requirement	48 ~ 95	75 ~ 145	145 ~ 270	210 ~ 400	260 ~ 520

Table 8 - TGS2442 alarm concentrations vs. performance standard requirements

Appendix

**TGS2442 Temperature Compensation Factors**  
*supplementary data*

V4 Input Value	Temp (°C)	KTemp Coefficient
4.15	-10	2.72
4.11	-9	2.64
4.06	-8	2.56
4.02	-7	2.49
3.97	-6	2.41
3.92	-5	2.34
3.87	-4	2.26
3.82	-3	2.19
3.77	-2	2.12
3.71	-1	2.06
3.66	0	1.99
3.60	1	1.93
3.54	2	1.87
3.49	3	1.81
3.43	4	1.76
3.37	5	1.70
3.31	6	1.65
3.25	7	1.60
3.19	8	1.55
3.13	9	1.51
3.06	10	1.46
3.00	11	1.42
2.94	12	1.38
2.88	13	1.34
2.81	14	1.30
2.75	15	1.27
2.69	16	1.24
2.63	17	1.20
2.56	18	1.17
2.50	19	1.14
2.44	20	1.12
2.38	21	1.09
2.32	22	1.07
2.26	23	1.04
2.20	24	1.02
2.14	25	1.00

V4 Input Value	Temp (°C)	KTemp Coefficient
2.09	26	0.980
2.03	27	0.961
1.97	28	0.943
1.92	29	0.926
1.86	30	0.909
1.81	31	0.894
1.76	32	0.879
1.71	33	0.865
1.66	34	0.852
1.61	35	0.839
1.56	36	0.827
1.52	37	0.816
1.47	38	0.805
1.43	39	0.795
1.38	40	0.786
1.34	41	0.776
1.30	42	0.768
1.26	43	0.759
1.22	44	0.752
1.18	45	0.744
1.14	46	0.737
1.11	47	0.730
1.07	48	0.724
1.04	49	0.718
1.01	50	0.712
0.975	51	0.706
0.944	52	0.701
0.914	53	0.696
0.885	54	0.692
0.857	55	0.687
0.830	56	0.683
0.803	57	0.679
0.778	58	0.675
0.753	59	0.671
0.729	60	0.668

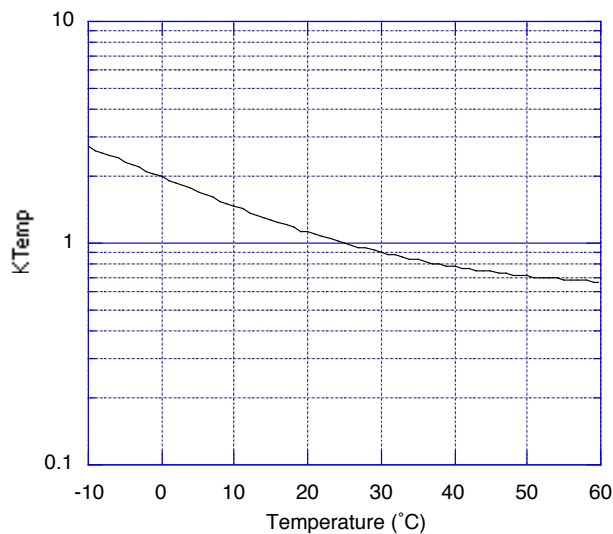

**FIGARO GROUP**

HEAD OFFICE

**Figaro Engineering Inc.**  
 1-5-11 Senba-nishi  
 Mino, Osaka 562 JAPAN  
 Tel.: (81) 72-728-2561  
 Fax: (81) 72-728-0467  
 email: figaro@figaro.co.jp

OVERSEAS

**Figaro USA Inc.**  
 121 S. Wilke Rd. Suite 300  
 Arlington Heights, IL 60005 USA  
 Tel.: (1) 847-832-1701  
 Fax.: (1) 847-832-1705  
 email: figarousa@figarosensor.com