

FIGARO

an ISO9001 company

Application Notes for LP Gas Detectors using TGS2610

The TGS2610 LP gas sensor has been presorted into groupings which will allow users to simplify the manufacturing process for LP gas detectors. This brochure offers example application circuits and important technical advice for designing and manufacturing gas detectors which use classified TGS2610 sensors.

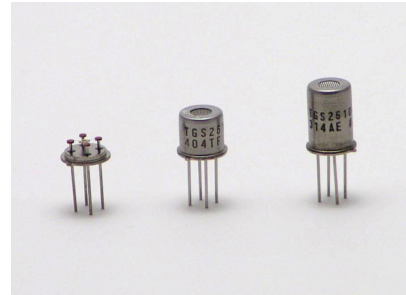

Page

Introduction.....2

Detector Circuit Design

- Basic Circuit with Temperature Compensation.....2
- Selecting a Load Resistor.....2
- Compensation for Internally Generated Heat.....3
- Heater Breakage Detection Circuit.....3
- Sensor Malfunction Detection Circuit.....3
- Prevention of Intermittent Alarming.....4
- Alarm Prevention during Warmup.....4
- Alarm Delay Circuit.....5
- Application Circuit.....5

Manufacturing Process

- Handling and Storage of Sensors.....5
- RL Selection.....5
- PCB Assembly.....5
- Sensor Assembly.....5
- Final Assembly.....6
- Preheating of Final Assembly.....6
- Gas Test.....6
- Storage of Finished Products.....6

Anticipated Performance at 10%LEL of Isobutane.....6

Pre-calibrated Sensor Module.....7

Appendix.....8

See also Technical Brochure ‘Technical Information on Usage of TGS Sensors for Toxic and Explosive Gas Leak Detectors’.

IMPORTANT NOTE: OPERATING CONDITIONS IN WHICH FIGARO SENSORS ARE USED WILL VARY WITH EACH CUSTOMER’S SPECIFIC APPLICATIONS. FIGARO STRONGLY RECOMMENDS CONSULTING OUR TECHNICAL STAFF BEFORE DEPLOYING FIGARO SENSORS IN YOUR APPLICATION AND, IN PARTICULAR, WHEN CUSTOMER’S TARGET GASES ARE NOT LISTED HEREIN. FIGARO CANNOT ASSUME ANY RESPONSIBILITY FOR ANY USE OF ITS SENSORS IN A PRODUCT OR APPLICATION FOR WHICH SENSOR HAS NOT BEEN SPECIFICALLY TESTED BY FIGARO.



TGS2610-C00 and -D00 are UL recognized components in accordance with the requirements of UL2075. Please note that component recognition testing has confirmed long term stability in 60ppm of propane; other characteristics shown in this brochure have not been confirmed by UL as part of component recognition.

To facilitate ease in manufacturing gas detectors, both Figaro TGS2610-C00 and TGS2610-D00 LP gas sensors are individually marked with an ID number (see Figure 1) indicating a factory presorted classification which corresponds to narrow ranges of sensor resistance in isobutane. When the sensor's ID number is properly used, the calibration process can be greatly simplified, eliminating long preconditioning time and the complicated handling of calibration gas.

1. Detector Circuit Design

1-1 Basic circuit with temperature compensation

Figure 2 shows an example of a basic circuit for gas detection, including temperature compensation for variations caused by ambient temperature fluctuations. Typical values for the circuit components are as follows:

- R_L : refer to Table 1
- R_{TH} : $5.0k\Omega (\pm 3\%)$, $B=4100 (\pm 5\%)$
- R_A : $7.50k\Omega (\pm 1\%)$
- R_B : $1.00k\Omega (\pm 1\%)$
- R_C : $4.42k\Omega (\pm 1\%)$

The values for components related to temperature compensation should be chosen so that V_{ref} is one-half of the V_c value at standard temperature ($20^\circ C$). The V_{ref} curve should approximate the temperature dependency curve of the V_{RL} when compensation is properly done.

1-2 Selecting a load resistor (R_L)

To optimize resolution of the output signal at the desired alarming concentration, it is necessary to adjust the resistance of the load resistor (R_L). It is recommended that R_L be selected at a value which is equal to the sensor's resistance (R_s) at the alarming concentration (i.e. $R_s/R_L = 1.0$). Please refer to the brochure "General Information for TGS Sensors" for more details.

Since the ID number corresponding to sensor resistance in isobutane gas is indicated on the sensor cap, the load resistor value can be selected according to Table 1. For example, for an alarm setting at 10% LEL, when using a sensor having an ID number of 7, the R_L value should be set at 1.27k Ω . By using the recommended R_L , the V_{RL} value at the alarming point typically will be 2.5V, which is equal to half of the circuit voltage (V_c).

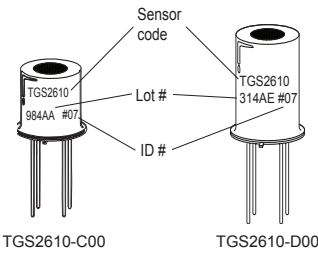

Fig. 1 - Sensor markings

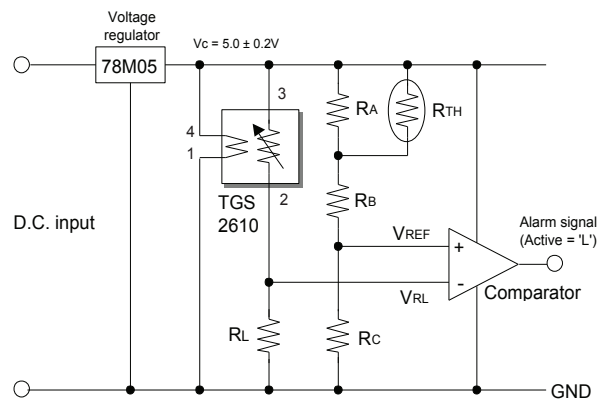

Fig. 2 - Basic circuit with temperature compensation

Sensor ID#	RL with $\pm 1\%$ tolerance			
	5% LEL	10% LEL	15% LEL	20% LEL
01	1.00	0.715	0.590	0.523
02	1.10	0.787	0.649	0.576
03	1.21	0.866	0.715	0.634
04	1.33	0.953	0.787	0.698
05	1.47	1.05	0.866	0.768
06	1.62	1.15	0.953	0.845
07	1.78	1.27	1.05	0.931
08	1.96	1.40	1.15	1.02
09	2.15	1.54	1.27	1.13
10	2.37	1.69	1.40	1.24
11	2.61	1.87	1.54	1.37
12	2.87	2.05	1.69	1.50
13	3.16	2.26	1.87	1.65
14	3.48	2.49	2.05	1.82
15	3.83	2.74	2.26	2.00
16	4.22	3.01	2.49	2.21
17	4.64	3.32	2.74	2.43
18	5.11	3.65	3.01	2.67
19	5.62	4.02	3.32	2.94
20	6.19	4.42	3.65	3.24
21	6.81	4.87	4.02	3.57
22	7.50	5.36	4.42	3.92
23	8.25	5.90	4.87	4.32
24	9.09	6.49	5.36	4.75

Table 1 - Recommended R_L by sensor ID

Note: Lower explosion limit (LEL) of isobutane = 18,000ppm

1-3 Compensation for internally generated heat

Depending on the design of the case and the PCB, there is often a difference between the temperature near the thermistor's placement in the detector and the ambient temperature. Therefore it is recommended to measure the actual temperature difference between the inside and the outside of the detector and select the value of R_C according to Table 2. When R_C is selected in this manner and used in the basic circuit (Figure 2), the result would be that $V_{ref}=1/2 V_c$.

ΔT ($^{\circ}C$)	R_C (k Ω)
0	4.42
5	4.02
10	3.57
15	3.24
20	2.94

$\Delta T = (\text{temp near thermistor}) - (\text{temp outside detector})$

Table 2 - Effect on selection of R_C by temperature differential inside and outside of detector

1-4 Heater breakage detection circuit

Figure 3 shows an example of how breakage of the sensor's heater wire and/or heater element can be detected. By adding R_E ($3.57\Omega \pm 1\%$) into the circuit and monitoring V_{RE} , a malfunction can be considered to have occurred when V_{RE} (0.2V typ.) drops to near 0V. Please note that a circuit voltage (V_c) of 5.2V should be applied to a circuit which incorporates a heater malfunction detection circuit.

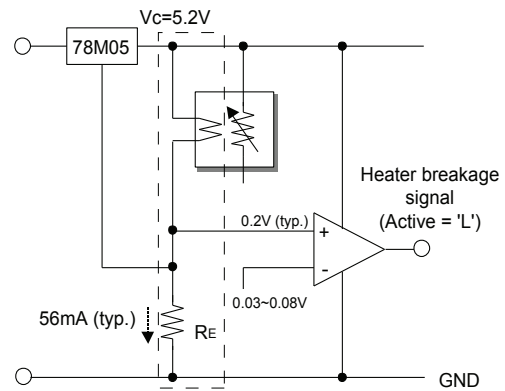

Figure 3 - Heater breakage detection circuit ($R_E = 3.57\Omega \pm 1\%$)

1-5 Sensor malfunction detection circuit

Breakage of lead wires to the sensor's electrodes and/or sensor element can be detected by using a circuit such as that shown in Figure 4. This involves replacing R_C with R_{C1} and R_{C2} , selecting their values so that $R_{C1}/R_{C2} \approx 50$. Since V_{RL} is normally greater than 50mV in any atmospheric conditions, by comparing V_{RL} to a reference voltage of 50mV, breakage of the lead wires and/or sensor element can be considered to have occurred if V_{RL} drops below 50mV.

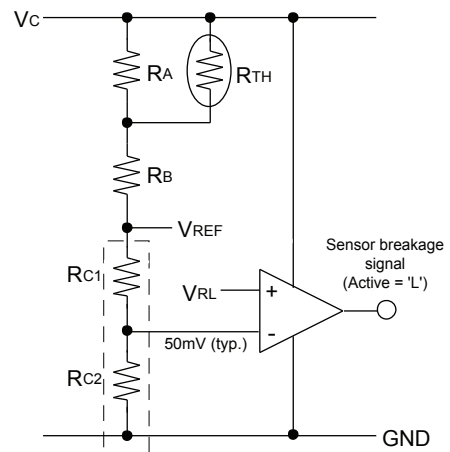

Figure 4 - Sensor malfunction detection circuit ($R_{C1}/R_{C2} \approx 50$)

1-6 Prevention of intermittent alarming

When gas concentration fluctuates right at the alarming threshold, dropping just below and rising just above, the detector would intermittently alarm in short bursts. In order to prevent the nuisance of intermittent alarming, a circuit such as that shown in Figure 5 can be used. By adding R_D to the original circuit, a Schmidt trigger circuit which includes a comparator can be created (the value of R_D should be set at 20-30 times that of R_C). As a result, a range for the alarming threshold is created. An alarm is then generated when the upper range of the threshold is breached and the alarm signal would cease after the signal drops below the lower end of the threshold range, thus eliminating frequent intermittent alarming.

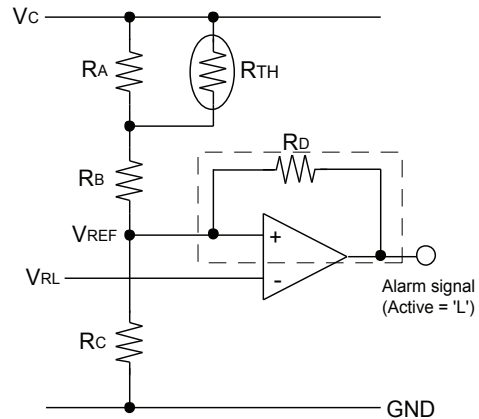

Figure 5 - Circuit for prevention of intermittent alarming ($R_D/R_C = 20\sim30$)

1-7 Alarm prevention during warm-up

As described in Sec. 2-6 of "Technical Information for TGS2610", when energizing the sensor after an unpowered period, the sensor's resistance (R_s) drops sharply for the first few seconds after energizing, regardless of the presence of gases, before recovering to a stable level. This 'initial action' may cause activation of an alarm during the first few moments of energizing since V_{RL} would exceed V_{ref} . To prevent this from happening, a circuit modification such as that shown in Figure 6 may be used. After powering the detector, sensor output (V_{RL}) should be set to zero for a pre-determined period (2.5 minutes is recommended--the timer function should be created by selecting the proper combination of C_3 and R_{11}). In order to restrict current to the sensor during this period, the recommended value of R_F should exceed $5k\Omega$.

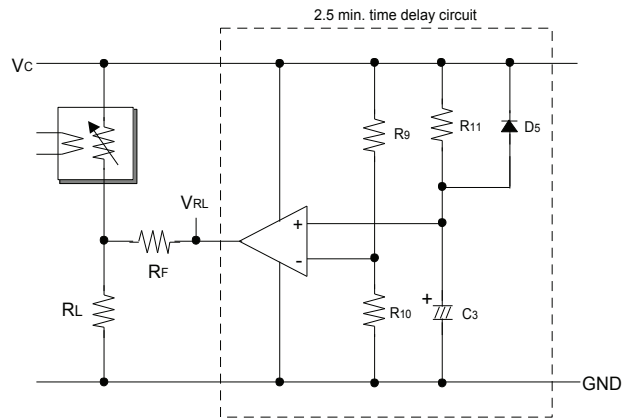

Figure 6 - Circuit for alarm prevention during warmup ($R_F > 5k\Omega$)

1-8 Alarm delay circuit

To prevent false alarms caused by transient interference gases such as alcohol in cooking vapors, a delay circuit modification such as that shown in Figure 7 can be used. The alarm signal generated by this circuit should be connected to the comparator in the basic circuit (see Figure 1). The recommended timer period for alarm delay is 15 seconds--the timer function should be created by selecting the proper combination of C4 and R15.

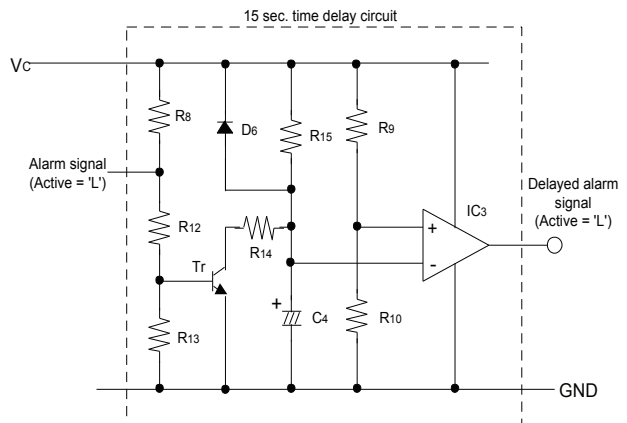

Figure 7 - Alarm delay circuit

1-9 Application circuit

An application circuit which incorporates all of the advice included in Secs. 1-1 through 1-8 can be seen in Appendix 1.

2. Manufacturing Process (see Fig. 8)

2-1 Handling and storage of sensors

Prior to usage, sensors should be stored at room temperature in a sealed bag containing normal clean air. During manufacturing, sensors should be handled in a clean air environment and at room temperature. Clean air refers to air free of contaminants, excessive dust, solvent vapors, etc. Room temperature should be 20~25°C.

2-2 RL selection

Choose the proper resistor for RL by referring to the ID number of the sensor and Table 1.

2-3 PCB assembly

Flux should be sufficiently dried before sensors are assembled onto the PCB to avoid any contamination of the sensor by flux vapors.

2-4 Sensor assembly

Manual soldering of the sensor to the PCB is strongly advised. Solders composed of Sn63:Pb37 or Sn60:Pb40 with non-chloric resin flux (MIL: RMA Grade; for example, Almit KR-19) are recommended for usage.

2-5 Final assembly

Avoid any shock or vibration which may be caused by air driven tools. This may cause breakage of the sensor's lead wires or other physical damage to the sensor.

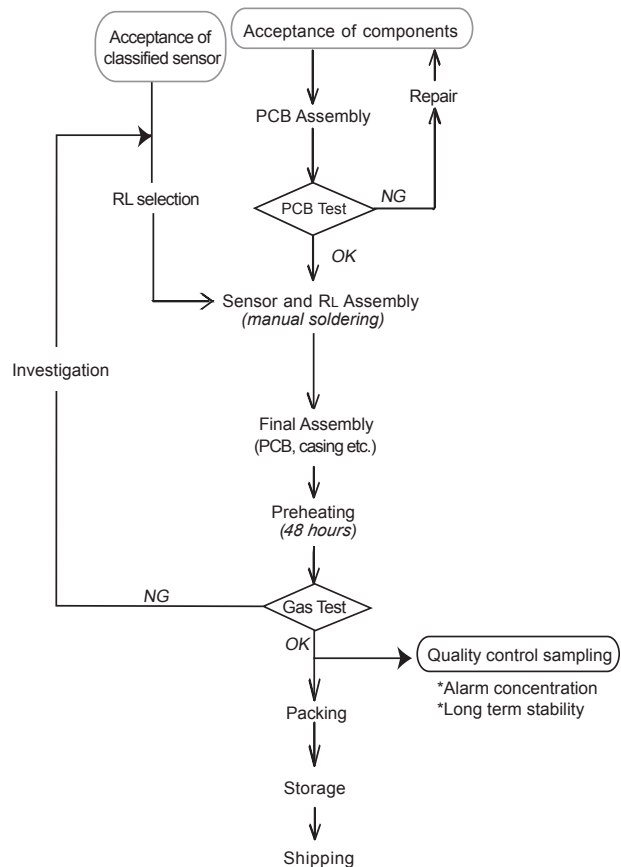

Figure 8 - Manufacturing process flowchart

2-6 Preheating of final assembly

To stabilize the detector assembly before gas testing, the minimum period for preheating final assemblies should be 48 hours at room temperature (20~25°C). Be certain to maintain clean atmospheric conditions for preheating.

2-7 Gas test

Test all finished products in the target gas under normal operating conditions. Keep the atmospheric conditions in the chamber stable, utilizing a user-defined standard test condition which is based on applicable performance standards and on anticipated usage for detectors. Remove any traces of smoke, adhesives, gases, or solvents from the chamber. **NOTE: Without testing after final assembly, detectors have no guarantee of accuracy or reliability.**

2-8 Storage of finished products

Detectors should be stored in a clean air environment at room temperature. Avoid storage in dirty or contaminated environments. Cautions listed in Sec. 6-1.3 of “General Information for TGS Sensors” should also be observed.

3. Anticipated Performance at 10%LEL of Isobutane

When using the classified TGS2610 with Figaro’s recommended RL for 10%LEL (Table 1) and temperature compensated circuit design (Figure 2), typical alarm tolerances for 10%LEL of isobutane such as those shown in Figure 9 are expected. Each RL classification contains a range of tolerance as exemplified by the alarming range labelled as ‘standard conditions’ (i.e these conditions are well-controlled). When factoring in the additional effects of environmental extremes and allowable variation in circuit conditions, the resulting alarming range would be typified by the range labelled as ‘operating conditions’. However, in actual usage, alarm thresholds may vary since the threshold is also affected by factors such as the tolerances of the thermistor and/or other components, load resistor value, test conditions, and heat generation inside the detector enclosure. As a result, Figaro neither expressly nor impliedly

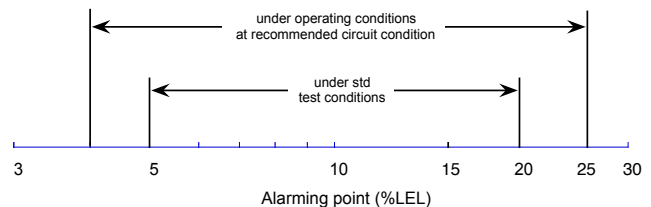

Figure 9 - Expected performance of isobutane detectors with classified TGS2610 & recommended RL for 10% LEL (refer to Table 3 for test conditions)

Temperature and humidity	Standard conditions	20±2°C, 65±5%RH
	Operating conditions	-10~40°C, 30~95%RH
Circuit conditions	Standard conditions	Vc=5.0±0.01V DC VH=5.0±0.05V DC
	Operating conditions	Vc=5.0±0.2V DC VH=5.0±0.2V DC
Conditioning prior to test		≥48 hours

Table 3 - Test conditions for measuring performance of isobutane detectors as shown in Figure 9

warrants the performance shown in Figure 9. If a large difference between the expected and actual performance of detectors is noticed, please consult with Figaro.

Pre-calibrated sensor module

Figaro has available a pre-calibrated isobutane sensor module LPM2610 (see Fig. 9). This module includes the classified TGS2610 sensor, a matched load resistor, and a factory preset temperature compensation circuit, all on a small PC board. The LPM2610 module is calibrated for a typical set point at 10% LEL, insuring performance as indicated in Table 3 by simply plugging it into a main PC board. Please refer to the brochure "Product Information for LPM2610" for detailed information.

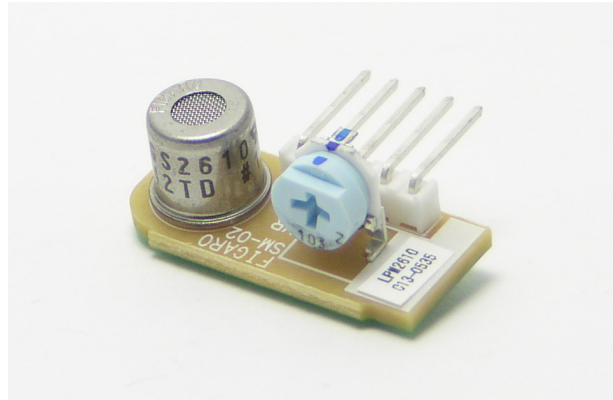

Figure 9 - Pre-calibrated sensor module LPM2610

Important Reminder

Without testing alarm threshold after final assembly, detectors have no accuracy or reliability guarantee.

Figaro USA Inc. and the manufacturer, Figaro Engineering Inc. (together referred to as Figaro) reserve the right to make changes without notice to any products herein to improve reliability, functioning or design. Information contained in this document is believed to be reliable. However, Figaro does not assume any liability arising out of the application or use of any product or circuit described herein; neither does it convey any license under its patent rights, nor

the rights of others.

Figaro's products are not authorized for use as critical components in life support applications wherein a failure or malfunction of the products may result in injury or threat to life.

FIGARO GROUP

HEAD OFFICE

Figaro Engineering Inc.

1-5-11 Senba-nishi
Mino, Osaka 562-8505 JAPAN
Tel.: (81) 72-728-2561
Fax: (81) 72-728-0467
email: figaro@figaro.co.jp
www.figaro.co.jp

OVERSEAS

Figaro USA Inc.

121 S. Wilke Rd. Suite 300
Arlington Heights, IL 60005 USA
Tel.: (1) 847-832-1701
Fax.: (1) 847-832-1705
email: figarousa@figarosensor.com

Appendix 1 - Example application circuit for gas detector using classified TGS2610

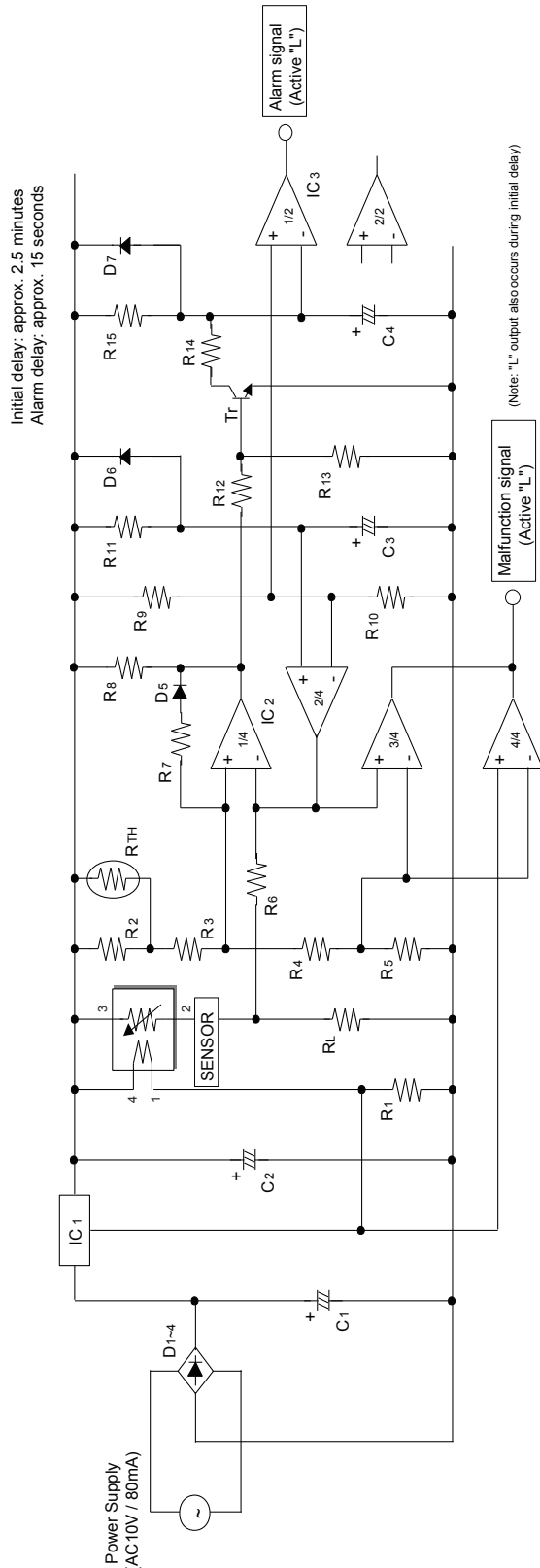

Part No.	Part name	Model No./ Specification	Maker	Part No.	Part name	Model No./ Specification	Maker	Part No.	Part name	Model No./ Specification	Maker
Sensor	Gas sensor	TGS2610	Figaro	D1	Rectification diode	S5566G	Toshiba	D2	Rectification diode	S5566G	Toshiba
R _{TH}	NTC thermistor	5kΩ, B=4100		D3	Rectification diode	S5566G	Toshiba	D4	Rectification diode	S5566G	Toshiba
R _L	Resistor	(See Table 1), 1%, 1/8W		D5	Small signal diode	1S1488	Toshiba	D6	Small signal diode	1S1488	Toshiba
R ₁	Resistor	3.57kΩ, 1%, 1/2W		D7	Small signal diode	1S1488	Toshiba	Tr	NPN transistor	2SC2603	Mitsubishi
R ₂	Resistor	7.5kΩ, 1%, 1/8W		IC1	Voltage regulator	MC78M05CT	Motorola	IC2	Comparator	LM339	Motorola
R ₃	Resistor	1.0kΩ, 1%, 1/8W		IC3	Comparator	LM393	Motorola				
R ₄	Resistor	4.32kΩ, 1%, 1/8W									
R ₅	Resistor	86.6Ω, 1%, 1/8W									
R ₆	Resistor	10kΩ, 5%, 1/8W									
R ₇	Resistor	130kΩ, 5%, 1/8W									
R ₈	Resistor	10kΩ, 5%, 1/8W									